



We're with you all the way.

INSTALLATION MANUAL

In order to give you prompt service and keep problems to a minimum, please handle any shortages or back charges according to the Procedures in the Preparation for Installation section of this manual.

Carefully check your packing list while unloading. Mark any items that appear to be missing and notify Customer Service as soon as possible.

Allied Steel Buildings
(877) 357-8335 (800) 595-9585 fax

Index

| | |
|---|-----------|
| 1 Introduction | 4 |
| 2 Foundation & Building Anchorage | 6 |
| 3 Preparation for Installation | 13 |
| 4 Unloading & Storing Materials | 17 |
| 5 Bolt Tightening Procedures | 22 |
| 6 Installation of Primary & Secondary Structural | 26 |
| 7 Sheeting Information | 36 |
| 8 Wall Insulation & Sheeting | 40 |
| 9 Roof Insulation & Sheeting | 44 |
| 10 Trim & Accessories | 59 |

DEFINITIONS OF TERMS USED IN THIS MANUAL:

Manufacturer - The Manufacturer in this manual is used to refer to the manufacturer, and includes all the divisions and subsidiaries of the manufacturer that may supply materials to the project.

Installer - The Installer is the company, entity, or individual who is responsible for assembling the building at the job site.

Builder - The Builder is the company or individual who purchases the building materials.

THE MANUFACTURER RESERVES THE RIGHT TO MODIFY ANY AND ALL DETAILS OR RECOMMENDATIONS OF THIS MANUAL WITHOUT INCURRING OBLIGATION.

IMPORTANT NOTE: Read and understand this page before proceeding with any work or further reading.

Safety First!

The Manufacturer has a commitment to manufacture quality building components that are designed to meet the structural requirements of the building. However, the safety commitment and job site practices of the installer are beyond the control of the Manufacturer and include expertise not possessed by the manufacturer.

It is urgently recommended that safe working conditions and accident prevention practices be the top priority on the job site, and that local, state and federal safety and health standards always be followed to help insure worker safety. These points cannot be stressed too strongly.

Job site safety is a joint responsibility of all parties present on the job site, including owners, architects, engineers, contractors, subcontractors, delivery personnel, and employees of all the above, among others. All should be watchful to avoid hazards that might cause damage to property or injury to any person, including himself or herself.

Always make certain all employees know the safest and most productive way of installing a building along with emergency telephone numbers, location of first aid stations and emergency procedures. Avoid working during inclement weather periods when personnel are at increased risk due to high winds, lightning, precipitation, etc.

The Manufacturer recommends daily meetings highlighting safety procedures, the use of hard hats, rubber sole shoes for roof work, proper equipment for handling material and appropriate safety gear, including nets where necessary.

This manual should be interpreted and administered with sound judgment consistent with good safety practices. Its information is to be disseminated to all workers on the job site. Ultimate safety guidelines and on-site provisions are the responsibility of all the parties on-site. Safety First!

INTRODUCTION:

The Manufacturer manufactures high quality, pre-engineered metal building packages. Quality installation is essential to complete the structure to the satisfaction of the building owner.

This manual has been prepared to help guide the installation process and reflects the techniques in use in the metal building industry believed to be most representative of good installation practices. These procedures and methods are by necessity general in nature. The installer should always use proven and safe installation methods.

This installation manual is intended only as a supplement to the Construction Drawings that are furnished with each building. The Construction Drawings show the building as engineered and fabricated according to information given to the Manufacturer. The Building Construction Drawings will always govern with regard to construction details and specific building parts. However, it may also be necessary for the Engineer of Record (not the Manufacturer) to prepare installation sequence drawings. Contact the Manufacturer's Customer Service Department to resolve any matters not addressed.

The information contained in this manual is believed to be reliable. However, the Manufacturer disclaims any responsibility for damages that may result from use of this manual since the actual installation operations and conditions are beyond the Manufacturer's control. **Only experienced, knowledgeable installers with trained crews and proper equipment should be engaged to do the installation.**

It is emphasized that the Manufacturer **is only a manufacturer** of metal buildings and components and is **not engaged** in the installation of its products. Opinions expressed by the Manufacturer about installation practices are intended to present only a guide as to how the components could be assembled to create a building. Both the quality and safety of installation and the ultimate customer satisfaction with the completed building are determined by the experience, expertise, and skills of the installation crews, as well as the equipment available for handling the materials.

The Metal Building Manufacturers Association's "CODE OF STANDARD PRACTICE" shall govern with respect to the fabrication tolerances, installation methods, and all fieldwork associated with the project in question. The installer should familiarize himself with the contents of this document. Additional copies may be requested at a nominal cost.

GENERAL FOUNDATION INFORMATION

The Manufacturer requires that an experienced foundation engineer design **all** building foundations, including pier sizes, grade beams and floor slabs. This engineer can also recommend excavation procedures, drainage practices, formwork, reinforcing steel requirements and concrete proportioning. This will assure proper designs, expedite the work, and reduce costs.

Proven construction techniques should be adhered to in the foundation work. The bottoms of all excavations should be level and smooth, and care should be taken to prevent cave-ins when utilizing the walls of the excavations for concrete forms. Strict adherence to **OSHA** and other local codes or laws governing “shoring of excavation to prevent accidental cave-ins” is critical. Where the ground surface is not level, the bottoms of the foundations should be in steps coinciding with the piers (as shown). Fill areas should be properly compacted to prevent settling cracks. Footing should extend below any fill material.

Care should be taken to obtain a good finish on the floor slab and to maintain the correct elevation throughout the slab. Pouring the slab in alternate sections, “checkerboard fashion”, can minimize shrinkage cracks. The outer corners of the foundation walls and piers should be sharply formed with straight sides and level tops. This will allow proper seating and good alignment of the base support member.

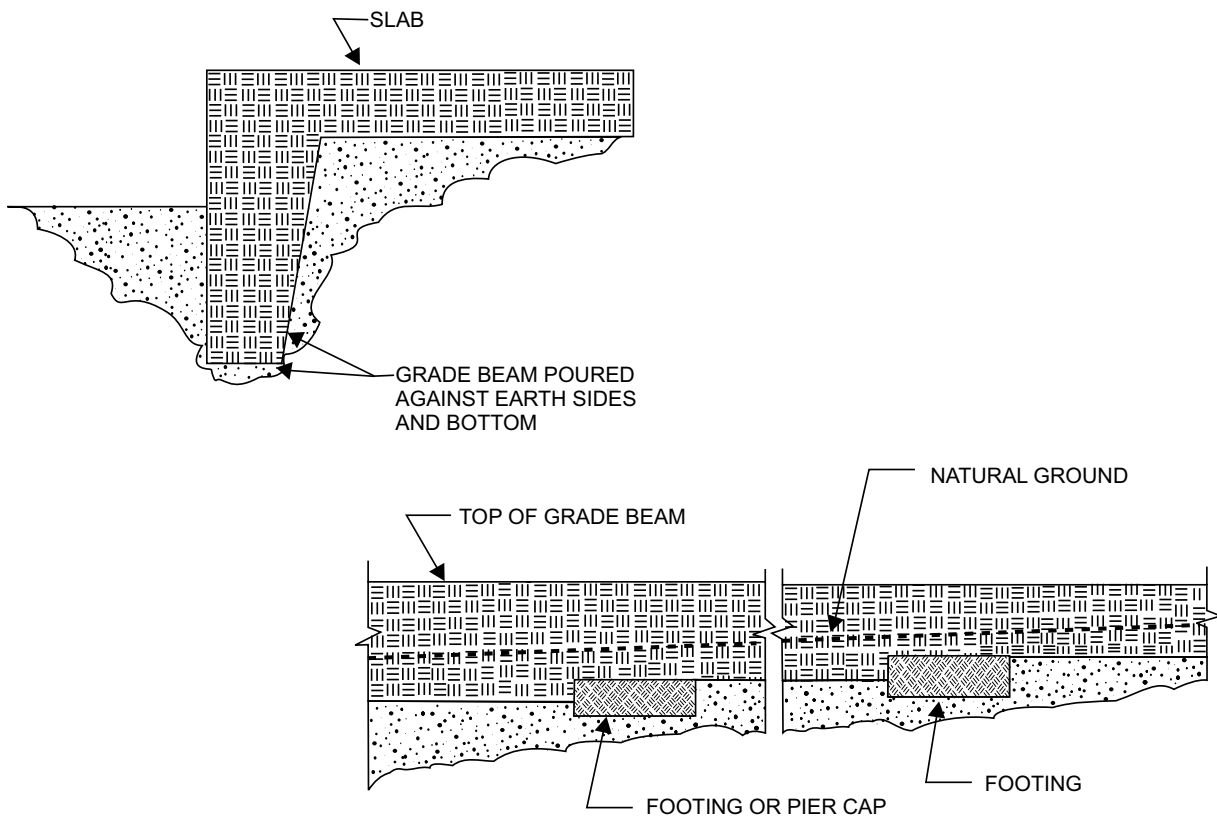

FOUNDATION CHECKING PROCEDURES

The importance of accurate foundation construction and anchor bolt settings cannot be over-emphasized. Foundation errors and mislocation of anchor bolts are among the most frequent and troublesome errors made in metal building construction. The following procedures and methods should help to minimize these costly errors and delays.

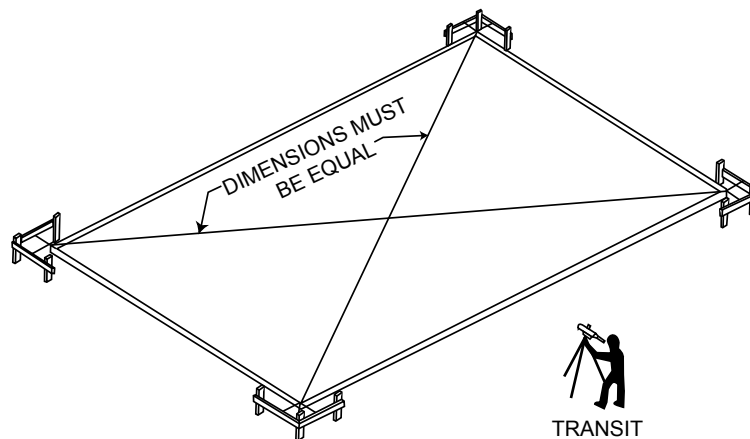

1. To determine that the foundation is square, measure diagonal dimensions to be sure they are of equal length.
2. To determine that the foundation is level, set up a transit or level and use a level rod to obtain the elevation at all columns.
3. Carefully check the location of all anchor bolts against the Anchor Bolt Setting Plan furnished by the Manufacturer. All dimensions must be identical to assure a proper start-up.

ANCHOR BOLT SETTINGS

It is extremely important that anchor bolts be placed accurately in accordance with the Anchor Bolt Setting Plan. All anchor bolts should be held in place with a template or similar means, so that they will remain plumb and in the correct location during placing of the concrete. Check the concrete forms and anchor bolt locations prior to the pouring of the concrete. **A final check should be made after the completion of the concrete work and prior to the steel installation.** This will allow any necessary corrections to be made before the costly installation labor and equipment arrives.

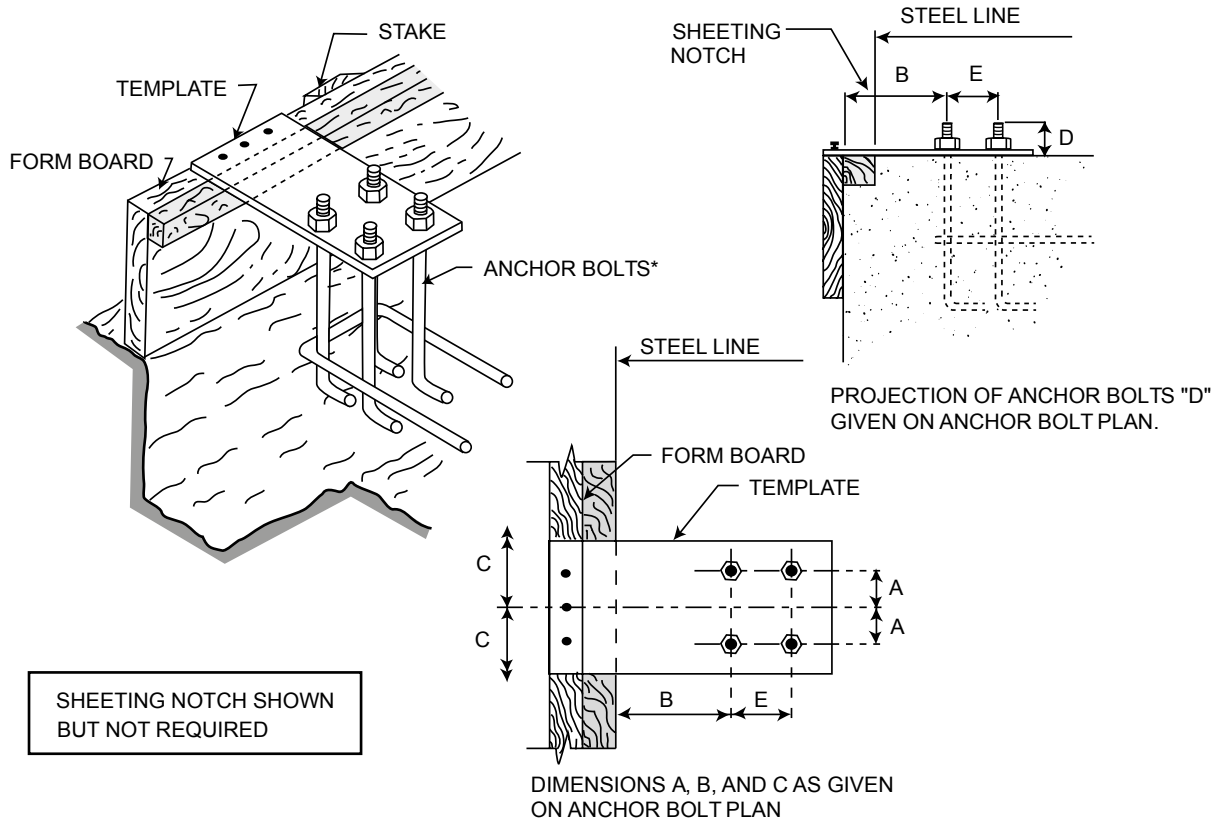

* Unless noted, anchor bolts are not by manufacturer.

TYPICAL DRAWING TYPES

TYPICAL ANCHOR BOLT PLAN

NOTE: Strict adherence to your specific anchor bolt plan is required. Foundation must be square and on plane! Make certain the anchor bolt plan being used is "For Construction", NOT "Preliminary".

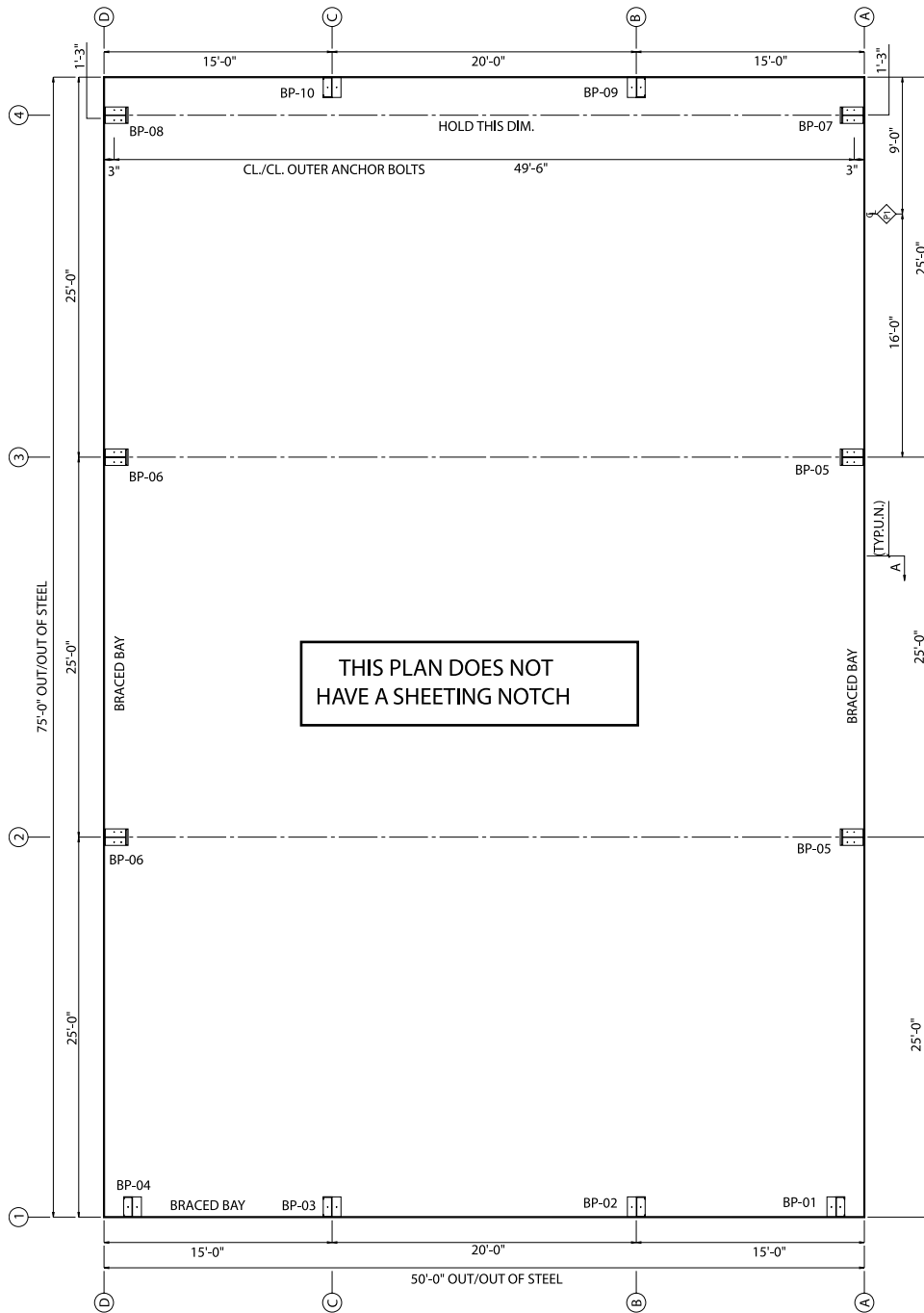

TYPICAL ANCHOR BOLT PLAN

RIGID FRAME CROSS SECTION

The typical section shows the column and rafter arrangement, purlin, girt and frame brace locations, bolt sizes and numbers, inside clearances and the layout of sidewall panels, roof panels and Light Transmitting Panels. The following illustrates a typical frame cross-section and a description of its contents.

1. Building steel width; dimension is out to out of girt line
2. Dimension from out of girt line to centerline of ridge; this dimension will be centerline dimension on symmetrical gable building
3. Depth of column web at column base
4. Total depth of column and girt at frame knee
5. Horizontal clear dimension of frame at knee connection
6. Building eave height; dimension measured from finished floor to top flange of eave strut
7. Girt spacing
8. Vertical clear dimension at knee connection, measured at bottom of connection plate
9. Roof slope
10. Slope dimension from centerline of ridge to out of eave strut measured along slope of roof at roof line
11. Purlin spacing
12. Roof panel types
13. Light transmitting panel locations (if applicable)
14. Web depths of all built-up members
15. Flange brace location
16. Roof panel endlap dimensions measured from purlin web line
17. Bolted frame splice designation

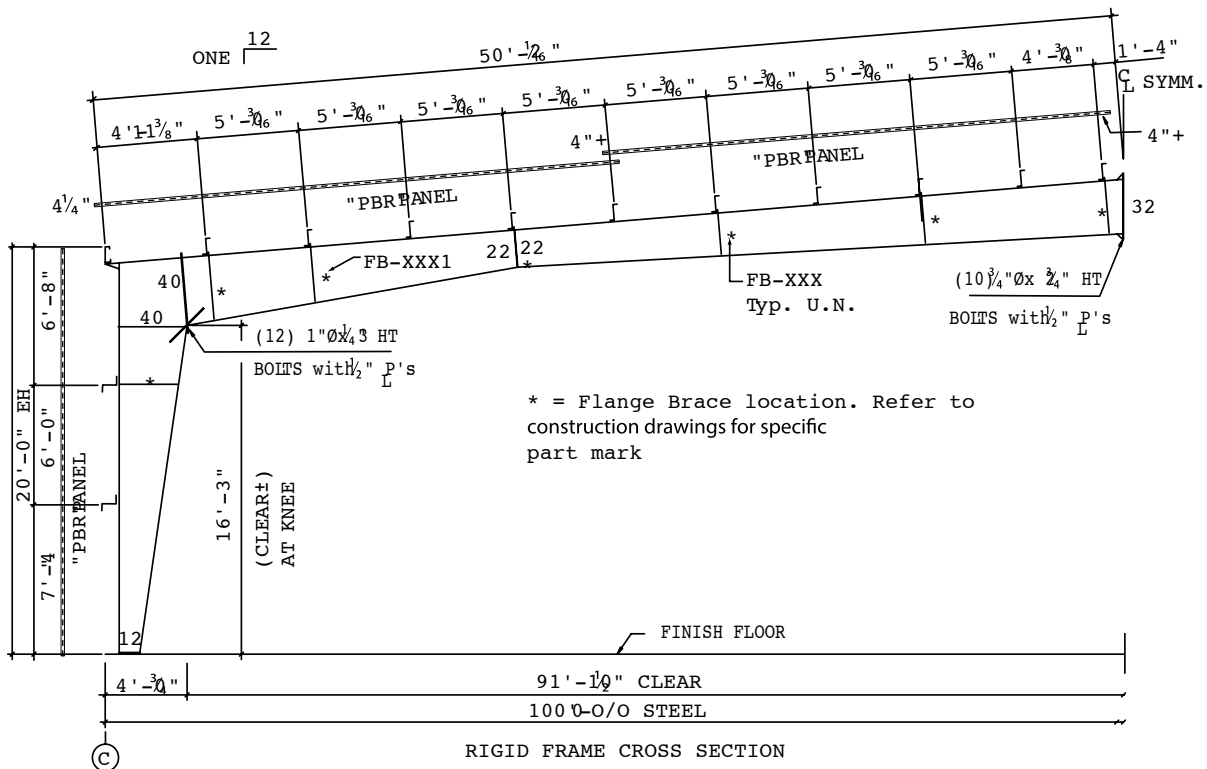

ROOF FRAMING PLAN

The roof framing plan shows the layout and part numbers of purlins, eave struts, bridging clips and bracing. A description of the contents on a typical roof-framing plan follows on the next page.

1. Building steel length shown out to out of purlins
2. Building steel width shown out to out of eave struts (or girts)
3. Sidewall column line designation (number)
4. Endwall column line designation (letter)
5. Sidewall bay spacing measured centerline to centerline of interior frames
6. Endwall exterior bay spacing shown on anchor bolt plan
7. Endwall interior bay spacing measured centerline to centerline of endwall columns
8. Purlin piece marks
9. Roof wind bracing piece marks
10. Eave strut piece mark
11. Downspout locations and/or maximum spacing
12. Knock-in-bridging spacing and piece marks (if applicable)
13. Purlin lap dimensions at interior bays

SIDEWALL FRAMING ELEVATION

The sidewall framing elevation shows the girts, eave struts and sidewall bracing layouts and part numbers. The contents of a typical sidewall elevation drawing are given below.

1. Building steel length measured out to out of endwall girts
2. Main frame end frame inset dimension; this dimension varies with end frame type and endwall girt depths, and is measured from outside of endwall girt to centerline of corner column
3. Sidewall bay spacing measured centerline to centerline of interior frames
4. Sidewall girt spacing
5. Eave strut piece mark
6. Sidewall girt piece mark
7. Sidewall bracing piece mark
8. Sidewall column line designation
9. Location of any shop located framed openings
10. Header and jamb piece marks (if applicable)

ENDWALL FRAMING ELEVATION

The endwall framing elevation shows the end framing column, rafter and girt arrangements and piece marks. Typical column and beam and rigid frame endwall framing elevations are explained below.

1. Endwall framing elevation designation by frame line number
2. Building steel width measured out to out of sidewall girts
3. Endwall exterior bay spacing
4. Endwall interior bay spacing measured centerline to centerline of endwall columns
5. Building eave height measured from top of finished floor to top flange of eave strut
6. Endwall girt spacing
7. Corner column piece mark

8. Endwall rafter piece mark
9. Endwall interior column piece mark
10. Endwall girt piece mark
11. Endwall column line designation (letter)
12. Location of any shop located framed openings
13. Header and jamb piece marks (if applicable)
14. Bolt size and quantity at endwall column to rafter connection

ACCESS TO SITE

The vehicle transporting your building parts must gain access to the building site from the adjacent highway or road. Such access should be studied and prepared in advance of arrival. All obstructions, overhead and otherwise, must be removed and the access route graveled or planked if the soil will not sustain the heavy wheel loads.

The availability of any required utilities should also be considered in advance. Take careful note of any overhead electric lines or other utilities to avoid hazards and damage (Notify your utility company(s) when necessary).

Develop a comprehensive safety awareness program in advance to familiarize the work force with the unique conditions of the site, and the building materials, along with the appropriate "Safe Work" practices that will be utilized.

NOTE: Complete sets of Construction Drawings are furnished with every building. Each plan is specially prepared for each individual building and should be strictly adhered to. Familiarize yourself and the crew with these drawings prior to start - up.

UNLOADING OPERATIONS

Pre- planning of the unloading operations is an important part of the installation procedure. This involves careful, safe and orderly storage of all materials. Detailed planning is required at the job site where storage space is restricted. Here, a planned separation of materials in the order of the installation process is necessary to minimize the costly double handling of materials. While set procedures are not possible in all cases, special attention should be given to the following items.

NOTE: The Manufacturer's trucks are loaded to maximize efficiency, maximize trailer weight, and insure safety. Unfortunately, the Manufacturer cannot load trucks per customer request.

SAFETY FIRST AT ALL TIMES!

1. Location of carrier vehicle during unloading

Unload materials near their usage points to minimize lifting, travel and rehandling during building assembly.

2. Prepare necessary ramp for truck

The edges of the concrete slab should be protected to minimize the danger of chipping or cracking from truck traffic if the materials are to be laid out on the slab. One important safety consideration is the fact that materials stored on the slab may subject the workers to possible injury from falling objects.

3. Schedule lifting equipment (not by the Manufacturer)

The type and size of lifting equipment is determined by the size of the building and the site conditions. Length of boom, capacity and maneuverability of lifting equipment will determine its location for both unloading and installation. You can use the same lifting equipment to unload and erect structural parts. Combining the unloading process with building installation usually minimizes lifting equipment costs. As soon as the truck is unloaded, the lifting equipment should be used to start installing the columns and raising the assembled rafters into position.

4. Consideration of overhead electric wires

Overhead power lines are a continuing source of danger. Extreme care must be used in locating and using lifting equipment to avoid contact with power lines.

5. Check shipment

When shipments are received in the field, the following procedures **MUST** be followed.

CUSTOMER SERVICE PROCEDURES

In order to give you prompt service and keep problems to a minimum, please handle any shortages or back charges in the following manner:

Carefully check your packing list while unloading. Mark any items that appear to be missing and notify the Manufacturer's Customer Service Department as soon as possible by telephone. Calling someone else could delay the proper response.

1. SHORT MATERIALS

Immediately upon delivery of material, quantities are to be verified by the Builder against quantities that are billed on the shipping document. Neither the manufacturer nor the carrier is responsible for material shortages against the quantities billed on shipping documents if such shortages are **not** noted **by the customer** on shipping documents when the material is delivered, and then acknowledged by the carrier's agent. A full inventory is to be conducted and shortages must be reported within 30 days of delivery. After 30 days the cost for materials and associated shipping charges are the customer's responsibility. If the carrier is the Manufacturer, the Builder must make claim for damage directly to the Manufacturer. If the material quantities received are correct according to the quantities that are billed on the shipping documents, but are less than the quantities ordered or the quantities that are necessary to complete the metal building according to the Order Documents, claim is to be made to the Manufacturer.

2. DAMAGED OR DEFECTIVE MATERIAL

Damaged or defective material, regardless of the degree of damage, must be noted on the shipping documents by the Builder and acknowledged in writing by the carrier's agent. The Manufacturer is not responsible for material damaged in unloading, nor for packaged or nested materials, including but not limited to, fasteners, sheet metal, "C " and " Z" sections and covering panels that become wet and/or damaged by water while in the possession of others. Packaged or nested material that becomes wet in transit must be unpacked, unstacked and dried by the Builder.

If the carrier is the Manufacturer, the Builder must make claim for damage directly to the Manufacturer.

If the carrier is a common carrier, the Builder must make the claim for damage to the common carrier. The Manufacturer is not liable for any claim whatsoever, including but not limited to, labor charges of consequential damages resulting from the Builders use of damaged or defective materials that can be detected by visual inspection.

3. EXCESSIVE MATERIAL

The Manufacturer reserves the right to recover any materials delivered in excess of those required by the Order Documents.

4. INITIAL CLAIM

In the event of error, the Builder must promptly make a written or verbal “Initial Claim” to the Manufacturer for the correction of design, drafting, Bill of Materials or fabrication error.

The “Initial Claim” includes:

- Description of the nature and extent of the errors, including quantities.
- Description of the nature and extent of proposed corrective work, including estimated manhours.
- Material to be purchased from other than the Manufacturer, including estimated quantities and cost.
- Maximum total cost of proposed corrective work and material to be purchased from other than the Manufacturer.

If the error is the fault of the Manufacturer, an “Authorization for Corrective Work” must be issued in writing by the Manufacturer to authorize the corrective work at a cost not to exceed the maximum total cost set forth.

Alternative corrective work other than that proposed in the “Initial Claim” may be directed by the Manufacturer in the “Authorization of Corrective Work.” Only the Customer Service Department may authorize corrective work.

5. FINAL CLAIM

The “Final Claim” in writing must be forwarded by the Builder to the Manufacturer within ten (10) days of completion of the corrective work authorized by the Manufacturer.

The “Final Claim” must include:

- Actual number of man-hours by date of direct labor use on corrective work and actual hourly rates of pay.
- Taxes and insurance on total actual direct labor.
- Other direct costs on actual direct labor.
- Cost of material (not minor supplies) authorized by the Manufacturer to be purchased from other than the Manufacturer, including copies of paid invoices.
- Total actual direct cost of corrective work (sum of 1, 2, 3 & 4). The “Final Claim” must be signed and certified true and correct by the Builder. “Final Claims” are credited to the Builder by the Manufacturer in an amount not to exceed the lesser of the maximum total cost set forth in writing in the “Authorization for Corrective Work” or total actual direct cost of corrective work.
- Cost of equipment (rental or depreciation), small tools, supervision, overhead and profit are not subject to claims.

6. STRUCTURAL FRAMING SHOP PRIMER

The primers supplied by ASB are not intended to provide the uniformity of appearance of a finish coat nor to provide extended protection if subjected to prolonged exposure. If immediate erection of steel is not possible, they must be protected from exposure to atmospheric and/or environmental conditions that may be detrimental to paint performance. These conditions would include, but not be limited to, prolonged exposure to ultra-violet light due to possible fading and or spotting or standing water resulting in spotting, peeling or localized surface oxidation.

The MBMA Commentary states that:

“...the manufacturer is not responsible for the deterioration of the shop coat of primer or corrosion that may result from exposure to atmospheric and environmental conditions, nor the compatibility of the primer to any field applied coating...”

The AISC, Code of Standard Practice further states that:

"...the shop coat of paint is the prime coat of the protective system. It protects the steel for only a short period of exposure..."

Primer touch-up due to transit abrasions and/or scratching during loading and unloading is to be expected. Primer touch-up is not the responsibility of ASB. Additional guidelines for the handling and storage of steel components can be found in both the MBMA Commentary and the AISC Code of Standard Practice.

The coat of shop primer is intended to protect the steel framing for only a short period of exposure to ordinary atmospheric conditions. The coat of shop primer does not provide the uniformity of appearance, or the durability and corrosion resistance of a field applied finish coat of paint over a shop primer. The Manufacturer is not responsible for deterioration of the shop coat of primer or corrosion that may result from exposure to atmospheric and environmental conditions, nor the compatibility of the primer to any field applied coating. Minor abrasions to the topcoat caused by handling, loading, shipping, unloading and installation after painting are unavoidable. Touch up of these minor abrasions is the responsibility of the Builder.

7. SHIPMENT ARRIVAL TIME

Every effort will be made to see that the carrier arrives at the job site on the requested day and at the requested hour. **Manufacturer makes no warranty and accepts no responsibility for costs associated with a shipment not arriving at a requested time unless a separate agreement has been made in writing for a guaranteed arrival time.**

These procedures are primarily for your protection. A shortage discovered later can be caused by theft, misplacement, or other causes, and neither the carrier nor the Manufacturer can accept responsibility.

NOTE: Galvanized and Galvalume Plus® materials are susceptible to damage from prolonged periods of contact with moisture while stacked together. If there is evidence of moisture during unloading, the panels should be separated, dried, and stored out of the weather to prevent permanent discoloration. Discolored Galvanized steel is not a reason for rejection of material. **Never install any material if its quality is in question.**

PRIMARY AND SECONDARY STRUCTURAL

A great amount of time and trouble can be saved if the building parts are unloaded at the building site according to a pre-arranged plan. Proper location and handling of components will eliminate unnecessary handling.

Inspect all shipments prior to releasing the tie-downs as loads may have shifted during transit!

REMEMBER, Safety First!

Blocking under the columns and rafters protects the splice plates and the slab from damage during the unloading process. It also facilitates the placing of slings or cables around the members for later lifting and allows members to be bolted together into sub-assemblies while on the ground. Extra care should always be exercised in the unloading operation to prevent injuries from handling the steel and to prevent damage to materials and the concrete slab.

If water is allowed to remain in bundles of primed parts such as girts, purlins, etc., the pigment will fade and the paint will gradually soften reducing its bond to the steel. Therefore, upon receipt of a job, all bundles of primed parts should be stored at an angle to allow any trapped water to drain away and permit air circulation for drying. Puddles of water should not be allowed to collect and remain on columns or rafters for the same reason.

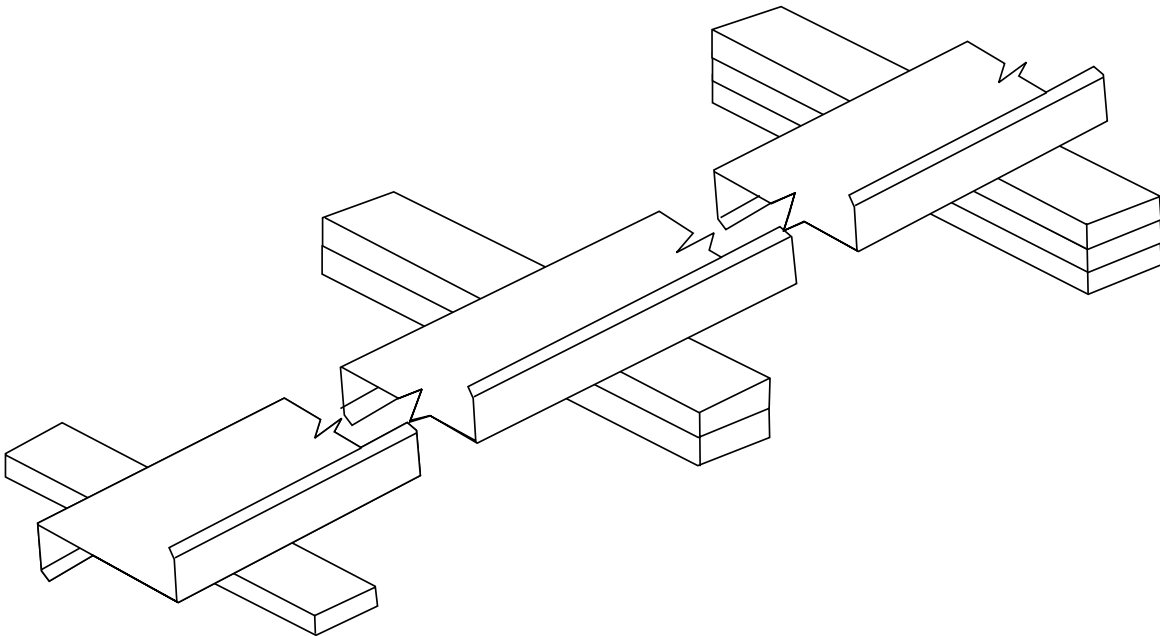

The coat of shop primer is intended to protect the steel framing for only a short period of exposure to ordinary atmospheric conditions. The coat of shop primer does not provide the uniformity of appearance, or the durability and corrosion resistance of a field applied finish coat of paint over a shop primer. The Manufacturer is not responsible for deterioration of the shop coat of primer or corrosion that may result from exposure to atmospheric and environmental conditions, nor the compatibility of the primer to any field applied coating. Minor abrasions to the shop coat caused by handling,

loading, shipping, unloading, and installation after painting are unavoidable. Touch-up of these minor abrasions is the responsibility of the Builder.

WALL AND ROOF SHEETING

The Manufacturer's wall and roof panels including color coated, Galvalume Plus®, and galvanized panels, provide excellent service under widely varied conditions. All unloading and installation personnel should fully understand that **these panels are quality merchandise, which merits cautious care in handling.**

Under no circumstances should panels be handled roughly. Packages of sheets should be lifted off the truck with extreme care to insure that no damage occurs to ends of the sheets or to side ribs. The packages should be stored off the ground sufficiently high to allow air circulation underneath the packages.

This avoids ground moisture and deters people from walking on the packages. One end of the package should always be elevated to encourage drainage in case of rain.

Moisture in contact with the surface of the panels can severely damage the finish and reduce the effective service life. Therefore, it is imperative that **all panels are inspected for moisture upon receipt of the order.** If moisture is present, dry the panels at once and store in a dry, warm place.

CAUTION: Care should always be taken when walking on panels. Always walk in the flat of the panel. Panels are slippery. Oil or wax that may have been applied to the roof and wall panels will make them a very slippery surface. Wipe dry any oil that has puddled from bundles stored on a slope. Dew, frost, or other forms of moisture greatly increase the slipperiness of the panels. Always assume panel surface is slippery and act accordingly. Never walk or step on light transmitting panels or translucent panels!

Safety First!

Use wood blocking to elevate and slope the panels in a manner that will allow moisture to drain. Wood blocking placed between bundles will provide additional air circulation. Cover the stacked bundles with a tarp or plastic cover leaving enough opening at the bottom for air to circulate.

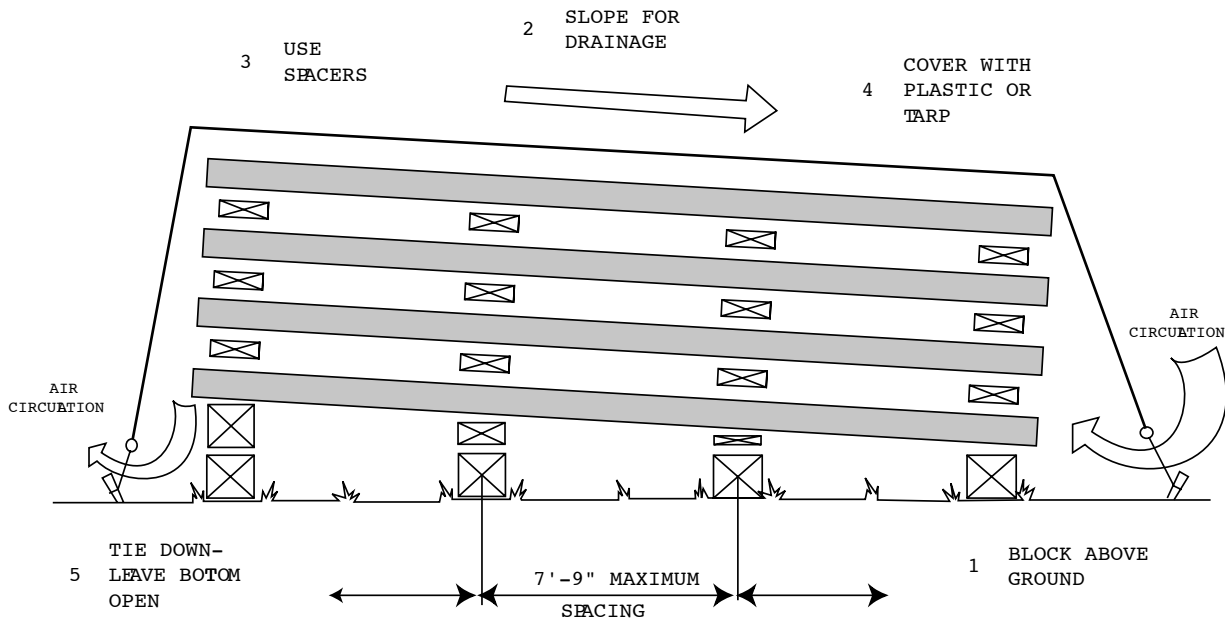

Burred edges may scratch the coated surfaces when sheets are slid over one another. Never allow panels to be walked on while on the ground.

The bottom sheet on each bundle is part of the total count and is not an "extra". Use caution when unloading and moving to prevent damage.

NOTE: Use gloves when handling metal panels to prevent hand injuries. Be aware of the dangers of handling panels on a windy day. A large panel can catch enough wind to knock a worker off his feet, even at ground level. Safety First!

UNLOADING

A crane and/or forklift are normally used for unloading the components of a metal building. Care should always be taken to avoid damaging material.

NOTE: Use caution when driving forklift over rough terrain to prevent panels from buckling.

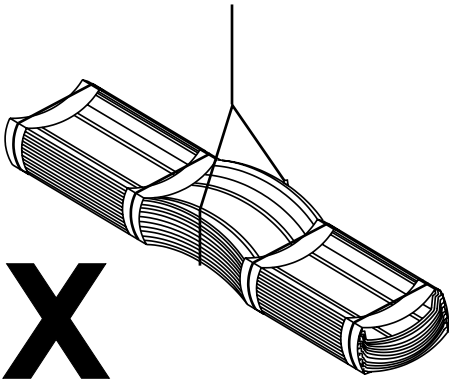

X

WRONG WAY

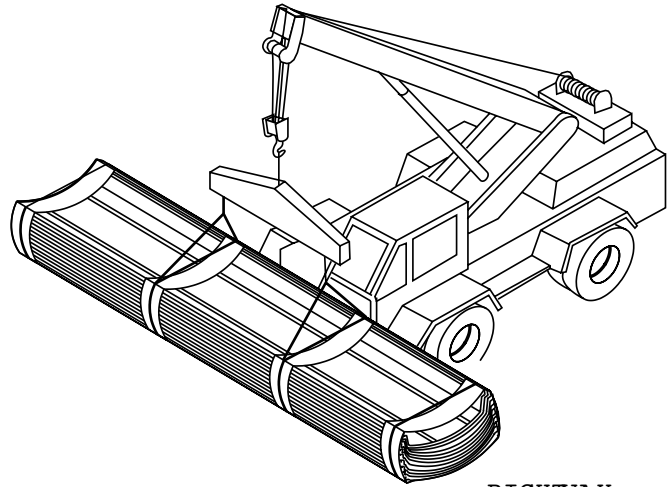

RIGHTWAY

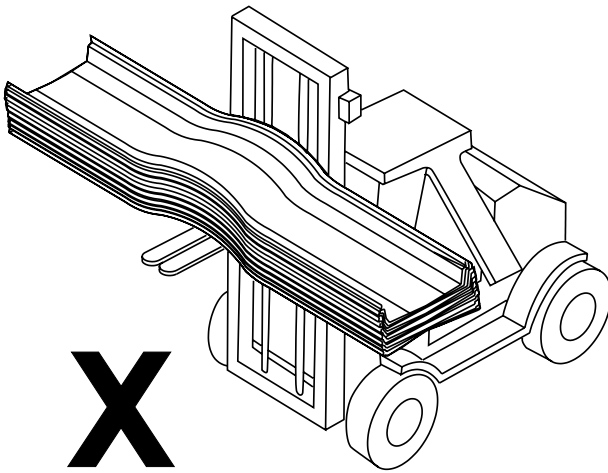

X

WRONG WAY

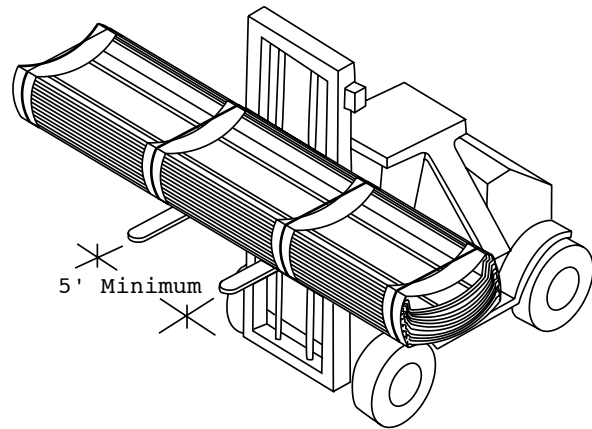

5' Minimum

RIGHTWAY

Always spread the forks as wide as possible to prevent the panels from bending. Even with the forks as wide as possible, it still may be necessary to lift certain loads with a crane or other auxiliary devices to avoid damaging material. When lifting bundles of sheeting or trim, the use of nylon belts is recommended to minimize damage to the materials. Always make sure bundles are adequately supported.

LOCATION OF BUILDING PARTS

- Columns and rafters are usually staged near the position in which they will be installed. They should be placed on blocking on the slab for easy makeup.
- Endwalls are usually laid out at each end of the slab with the columns near respective anchor bolts.

NOTE: An access area through the center of the building should be left for installation equipment.

- Hardware packages should be located centrally, usually along one sidewall near the center of the building. This will minimize walking distances to other parts of the slab area.
- Purlins and girts, depending on the number of bundles, are usually stored near the sidewalls clear of other packages or parts.
- Sheet packages are usually located along one or both sidewalls off the ground and sloping to one end to encourage drainage in case of rain.
- Accessories are usually unloaded on a corner of the slab or off the slab near one end of the building to keep them as much out of the way as possible from the active area during steel installation.

NOTE: Steps must be taken to protect the entire job site from vandalism and pilferage.

CONNECTION BOLTS

Bolts used to make connections in primary framing members such as columns and rafters are usually ASTM A325 bolts. Bolts used to make connections in secondary framing members such as the purlins are usually ASTM A307 bolts. The size and grade of the bolts are marked on the Building Construction Drawings.

The following information is copied from the AISC ninth edition, "Specification For Structural Joints Using ASTM A325 or A490 Bolts". This is provided to you only as a guide. **It is the responsibility of you as the installer to assure proper tightness of all bolts.**

Turn-of-Nut Tightening

When turn-of-nut tightening is used, hardened washers are not required except [*as otherwise indicated on the Construction Drawings*].

A representative sample of not less than three bolts and nuts of each diameter, length, and grade to be used in the work shall be checked at the start of work in a device capable of indicating bolt tension. The test shall demonstrate that the method of estimating the snug-tight condition and controlling turns from snug tight to be used by the bolting crews develops a tension not less than five percent greater than the tension required by Table 4.

Bolts shall be installed in all holes of the connection and brought to a snug tight condition. Snug tight is defined as the tightness that exists when the plies of the joint are in firm contact. This may be attained by a few impacts of an impact wrench or the full effort of a man using an ordinary spud wrench. Snug tightening shall progress systematically from the most rigid part of the connection to the free edges, and then the bolts of the connection shall be retightened in a similar systematic manner as necessary until all bolts are simultaneously snug tight and the connection is fully compacted. Following this initial operation all bolts in the connection shall be tightened further by the applicable amount of rotation specified in Table 5. During the tightening operation there shall be no rotation of the part not turned by the wrench. Tightening shall progress systematically from the most rigid part of the joint to its free edges. Impact wrenches, if used, shall be of adequate capacity and sufficiently supplied with air to perform the required tightening of each bolt in approximately 10 seconds.

Table 4. Fastener Tension Required for Slip-critical Connections and Connections Subject to Direct Tension

| Nominal Bolt Size, Inches | Minimum Tension ^a in 1000's of Pounds (kips) | |
|---------------------------|---|------------|
| | A325 Bolts | A490 Bolts |
| 1/2 | 12 | 15 |
| 5/8 | 19 | 24 |
| 3/4 | 28 | 35 |
| 7/8 | 39 | 49 |
| 1 | 51 | 64 |
| 1 1/8 | 56 | 80 |
| 1 1/4 | 71 | 100 |
| 1 3/8 | 85 | 121 |
| 1 1/2 | 103 | 148 |

^aEqual to 70 percent of specified minimum tensile strengths of bolts (as specified in ASTM Specifications for tests of full size and A490 bolts with UNC threads loaded in axial tension) rounded to the nearest kip.

A325

Table 5. Nut Rotation from Snug Tight Condition ^{a,b}

| Bolt length (under side of head to end of bolt) | Disposition of Outer Face of Bolted Parts | | |
|--|---|--|---|
| | Both faces normal to bolt axis | One face normal to bolt axis and other sloped not more than 1:20 (beveled washer not used) | Both faces sloped not more than 1:20 from normal to the bolt axis (beveled washer not used) |
| Up to and including 4 diameters | 1/3 turn | 1/2 turn | 2/3 turn |
| Over 4 diameters but not exceeding 8 diameters | 1/2 turn | 2/3 turn | 5/6 turn |
| Over 8 diameters but not exceeding 12 diameters ^c | 2/3 turn | 5/6 turn | 1 turn |

^aNut rotation is relative to bolt regardless of the element (nut or bolt) being turned. For bolts installed by $\frac{1}{2}$ turn and less, the tolerance should be plus or minus 30 degrees; for bolts installed by $\frac{2}{3}$ turn and more, the tolerance should be plus or minus 45 degrees.

^bApplicable only to connections in which all material within the grip of the bolt is steel.

^cNo research has been performed by the Council to establish the turn-of-nut procedure for bolt lengths exceeding 12 diameters. Therefore, the required rotation must be determined by actual test in a suitable tension measuring device which simulates conditions of solidly fitted steel.

Turn-of-Nut Sequence Order

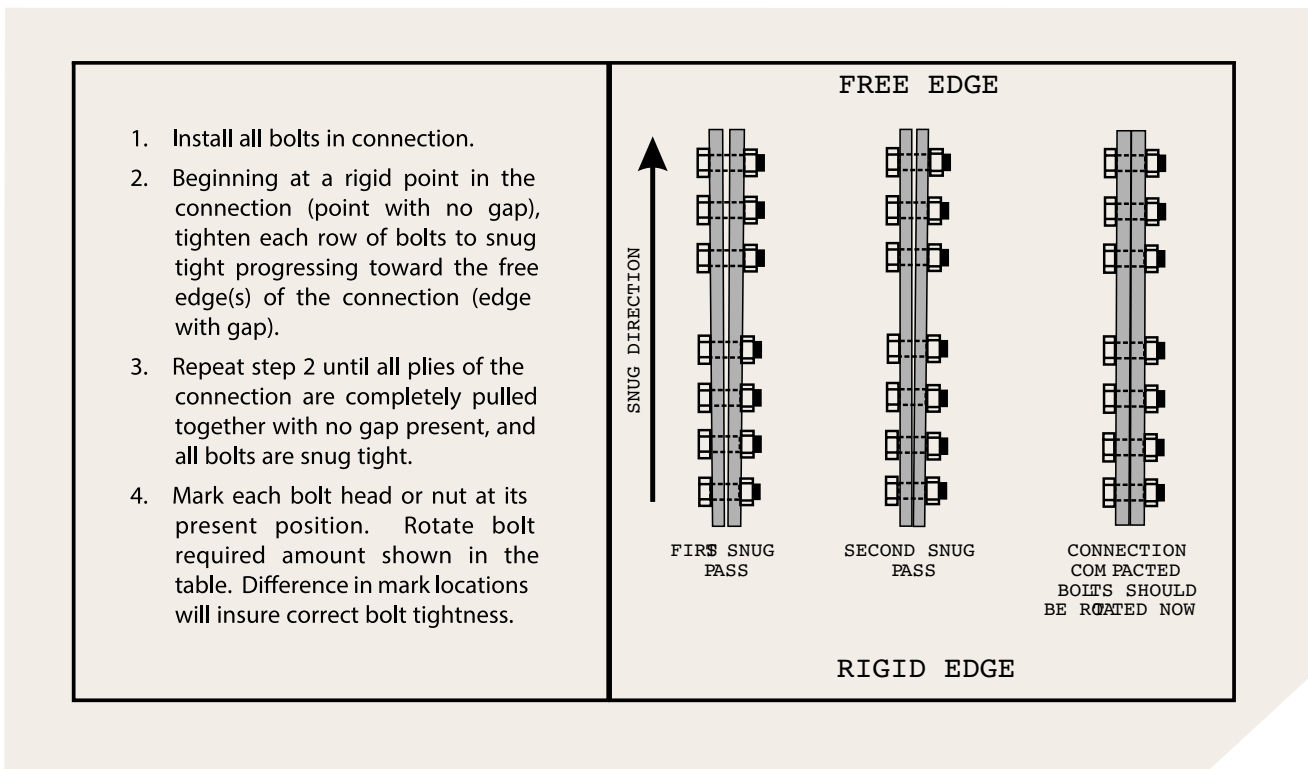

Turn-of-Nut Procedure

When connection is compacted and bolt is snug:

1. Mark nut and bolt location with keel or chalk.
2. Rotate nut as required per chart conditions.
3. Finished mark locations are proof that bolts have been properly tightened.

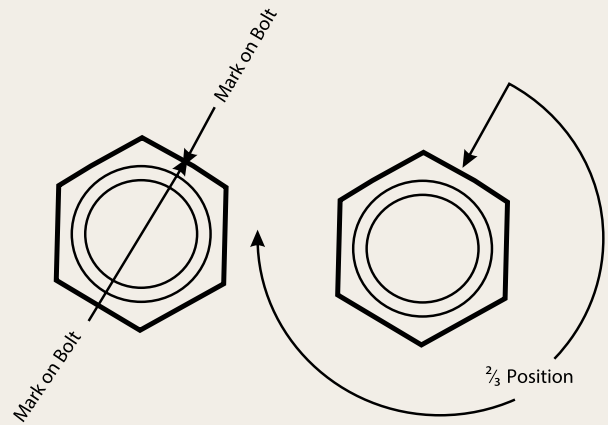

GENERAL INFORMATION

Many methods and procedures are in use for installing the structural portion of metal buildings. The techniques of raising frames vary from installing small clear spans and endwall frames in units to installing the larger clear spans and modular frames in sections. The installation methods used depend strictly on the type of building, the available equipment, the experience level of the crews, and the individual job conditions.

NOTE: Do not install any material if its quality is in question. The Manufacturer will not be responsible for incurred costs associated with the installation and/or removal of the questionable material.

The variation in these factors precludes the establishment of a firm or specific set of installation rules and procedures. Consequently, the installer must tailor the installation operation to fit individual conditions and requirements. However, there are certain installation practices, pertaining to structural members, which are in general use and have proven sound over the years.

Installers are directed not to cut primary members (rigid frame columns, rafters, end bearing frame rafters, interior columns). These are the primary support members for the frame and are designed as such. Any cutting of these members will affect the structural stability. A representative of the Manufacturer must be consulted prior to attempting alterations of these members.

NOTE: In no case should building installation be started on uncured concrete. Anchor bolts may pull loose, concrete spall (chip out along edges) may occur and equipment may crush or crack slab. Normal Portland Cement concrete should cure at least seven days and high-early-strength concrete at least three days before the structural columns are erected. Special circumstances may require even longer curing periods. Consult the project engineer, not the Manufacturer on foundation questions.

RECOMMENDED TOOLS

When buying tools for building installation, it is recommended that only industrial rated, top quality tools be purchased. Experience shows that lighter duty tools, although cheaper initially, will not hold up satisfactorily. In the long run, the tools will cost more, not only in repairs, but also in lost time. High-speed drill bits are always recommended since carbon steel bits will not give satisfactory service. Most installers find that short jobbers length bits are more economical and rugged than standard length bits.

Maintaining equipment and tools in safe, clean first class condition reduces injuries, lowers replacement expense, and encourages workers to take better care of equipment and greater pride in their work.

NOTE: Make certain that the correct tool is available and used for each phase of building installation. Improper tool usage results in employee injury. All tools used should be OSHA approved for commercial construction use.

Safety First!

RIGGING SLINGS

Shown below are methods that may be used for rigging slings for lifting roof beam assemblies.

Regardless of the method you use, make sure it is suitable and adequate for the job when considering the weight and size of the roof beam assemblies and hoisting equipment available.

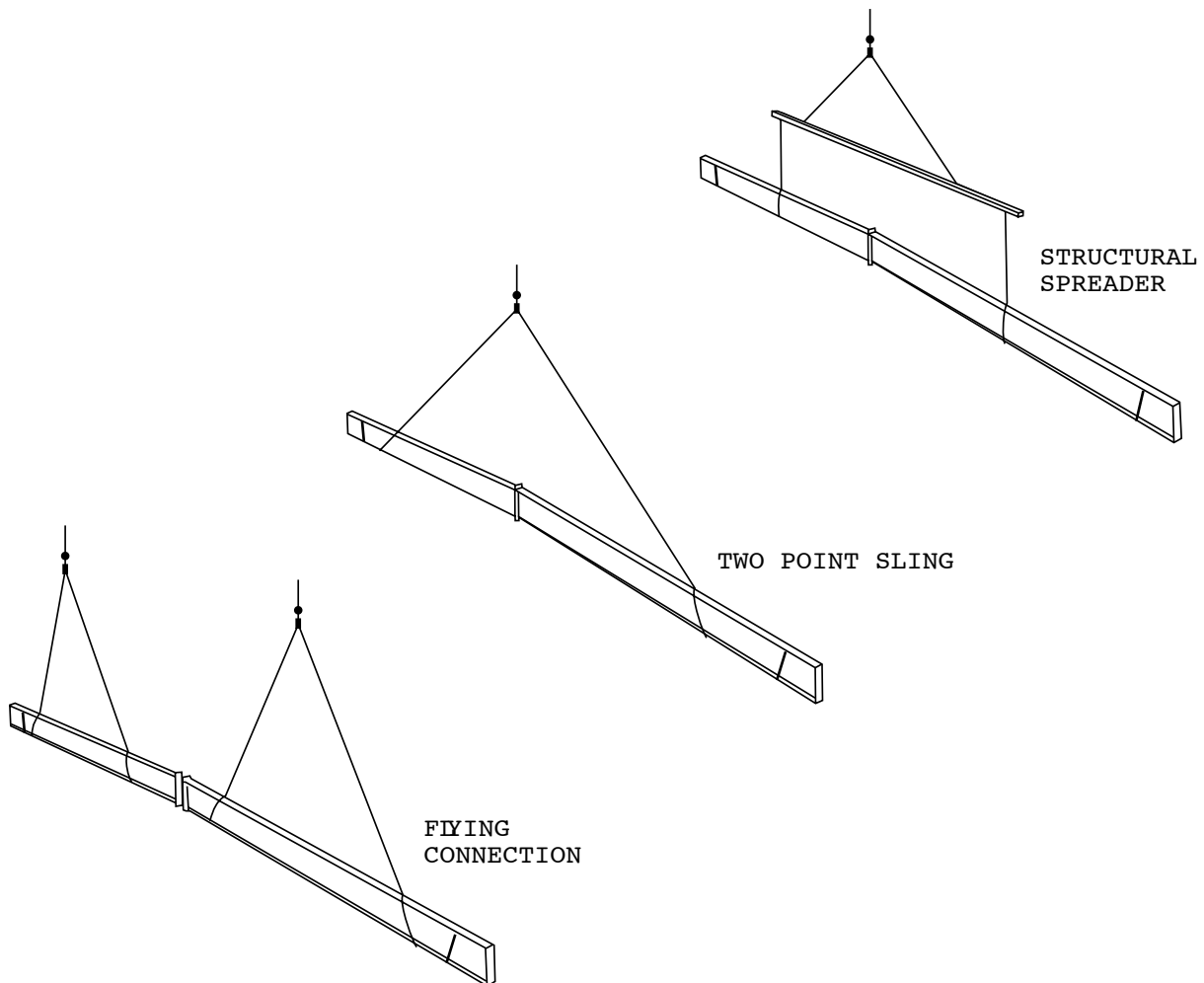

When the rafters consist of several roof beams, as in the case of wide buildings, a safe procedure of raising by sections and supporting the free end must be followed, regardless of the type of equipment available. In most instances the work proceeds from the outside columns inward toward the peak until the entire frame is bolted into place.

The same general procedures of installation apply to either clear span or multiple span frames. In the case of the latter, the support for rafter sections during installation is generally supplied by the interior columns themselves, making temporary supports unnecessary.

Two words of caution concerning the installation of rigid frames is in order. The first is that rigid frames, especially free ends or cantilevered sections should never be left for the day in an unsupported, unbraced, or unguaged condition. Such practice has resulted in the total loss of considerable amounts of installed steel because of wind. The second word of caution pertains to the additional care required in the installation of multiple span frames compared to clear span frames. Frames with interior columns, because of closer supports, have much lighter sections. They are much more apt to buckle during installation than clear span frames, and consequently require greater care in rigging and handling.

NOTE: Each worker should be trained to use the safest and most productive installation techniques.

Safety First!

INSTALLATION PROCEDURE

IMPORTANT: This installation procedure is provided as a general guide only and does not address other acceptable methods of installation. Installation procedures and safety precautions are the responsibility of the installer. The installer must in all cases comply with all applicable safety precautions whether statutory, regulatory, or customary. Procedures depicted in this manual are drawn from general practice and may not apply in every case. Furthermore, even the most common practices may result in injury or improper installation if not conducted properly and under the supervision of an appropriate professional. The manufacturer will not be held liable for problems stemming from improper installation.

Many devices (such as a transit) and materials (such as temporary bracing shown) are assumed to be available on a typical construction site and are not provided by the manufacturer.

STEP 1

1. Check anchor bolts against Anchor Bolt Setting Plan. Check Anchor Bolt Setting Plan and Construction Drawings for special conditions. Stand columns and attach girts.
2. Installer shall determine the number of girts and temporary bracing (Not by Manufacturer) required to secure columns.

NOTE:

1. Plan to install a braced bay first. Usually this is the first interior bay from either end of the building.
2. Refer to bolt tightening section of this manual for the turn-of-nut method of tightening bolts.
3. Bolt in place as many clips and flange braces as possible before raising frame to reduce in-the-air installation time.
4. It is the responsibility of the installer to provide temporary installation bracing until the structure is complete.
5. Install wind bracing. Diagonal bracing in metal buildings is critical! Additional temporary bracing is needed to stabilize the structure during installation. On some smaller buildings, diagonal bracing is not needed for the building design. All bracing should be installed to a taut condition removing all slack. **DO NOT OVER TIGHTEN.** Any modification to bracing shown on the Construction Drawings must be approved by the Manufacturer.
6. Field slotting of girts will be required for installation of diagonal bracing when a flush girt condition exists.

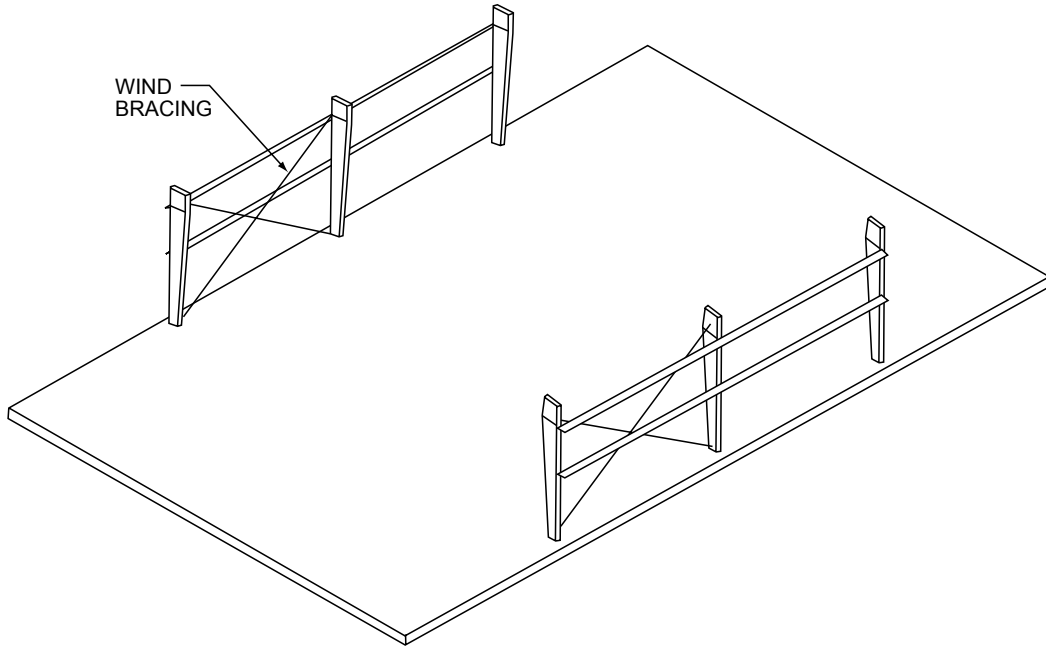

INSTALLATION OF THE WIND BRACING

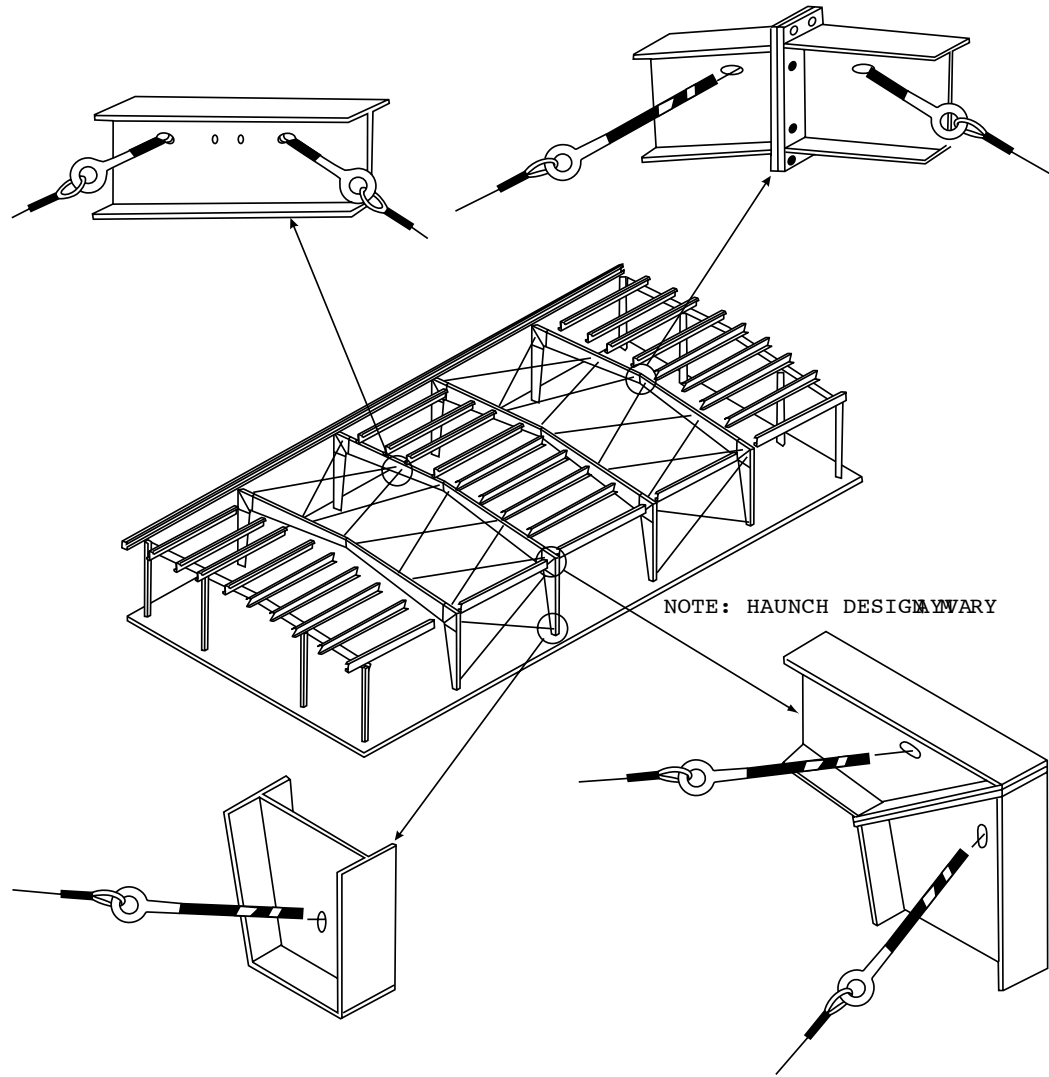

NOTE: HAUNCH DESIGN VARY

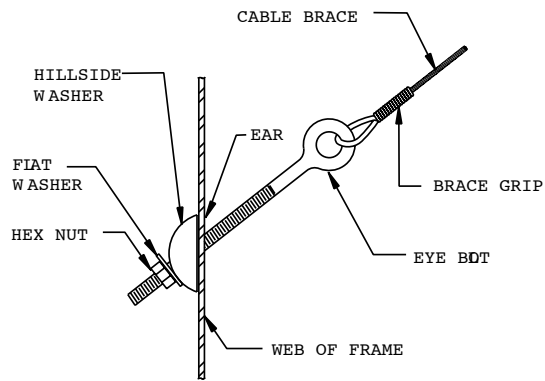

CABLE BRACE
FRAME CONNECTION

NOTE: BE SURE THE EAR OF WASHER IS LOCKED TO ISLCT.

STEP 2

1. Stand endwall column and attach girts.
2. Bolt flange brace to rafter before raising.
3. Raise first rafter beam and haunch frame section into place. All high strength bolts are to be tightened before raising.
4. Hold in place until this section is secured to columns and temporary bracing is tied off to hold frame in place. It is allowable to attach the temporary bracing (Not by Manufacturer) to the anchor bolts.

NOTE: Temporary bracing is used at the discretion of the installer. It is the responsibility of the installer to provide adequate temporary bracing.

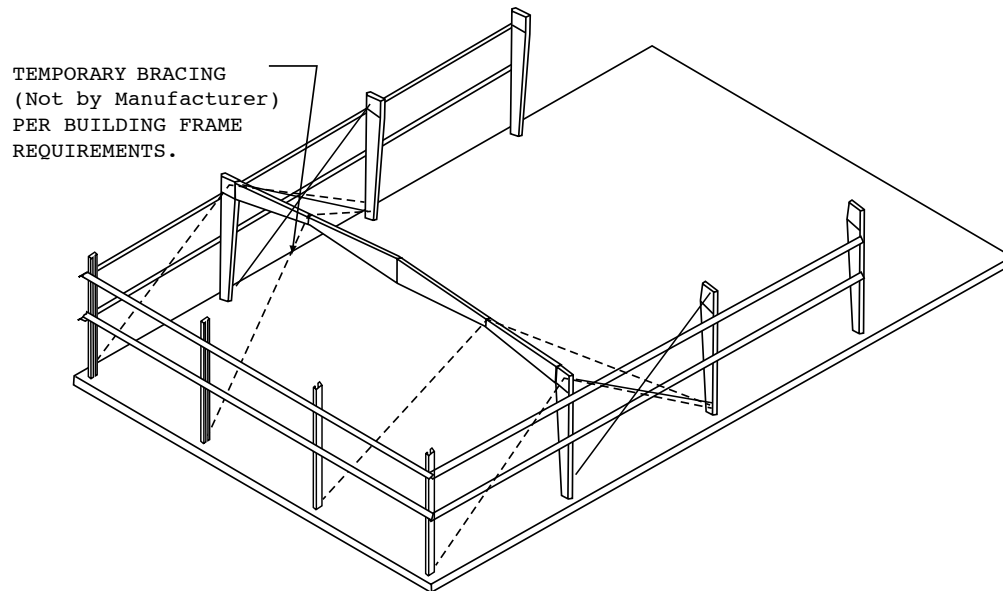

STEP 3

1. Raise second haunch and rafter beam frame section.
2. Hold in place until this section is bolted to columns, and lead purlins have been attached.
3. Finish installing flange braces to purlins as soon as the purlin has been installed. Install purlins $\pm 20'$ O.C. with flange brace.

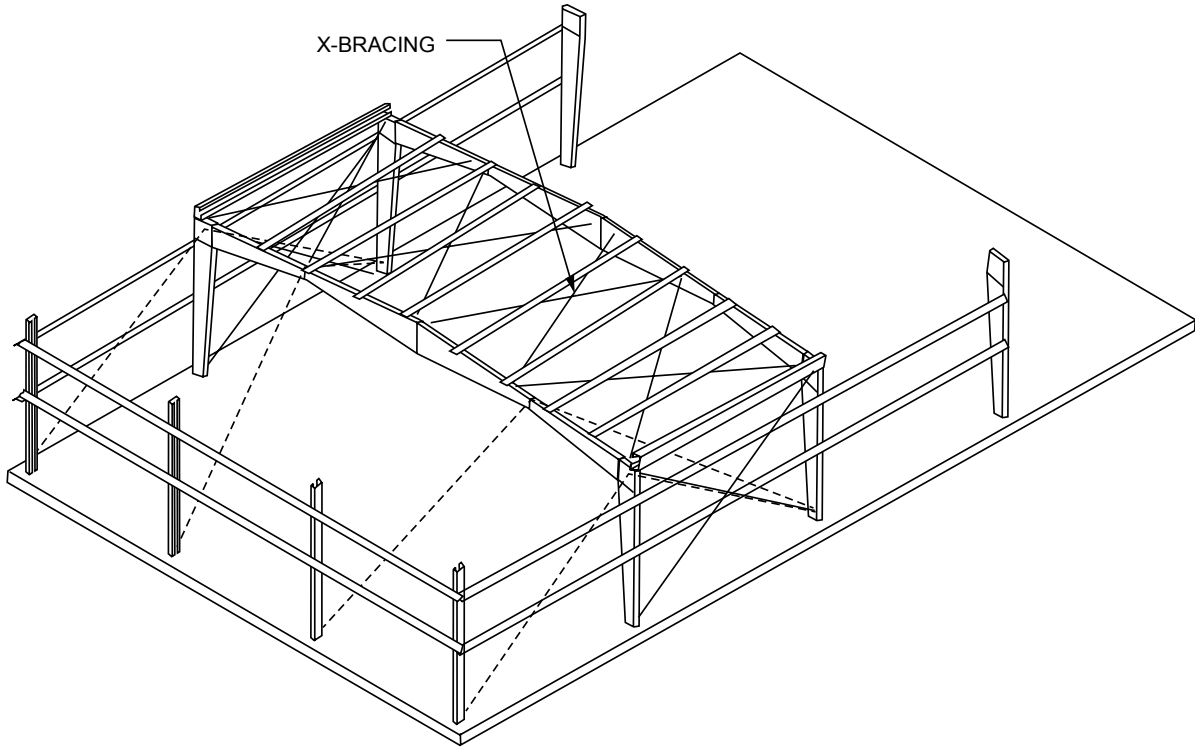

INSTALLATION OF FLANGE BRACING

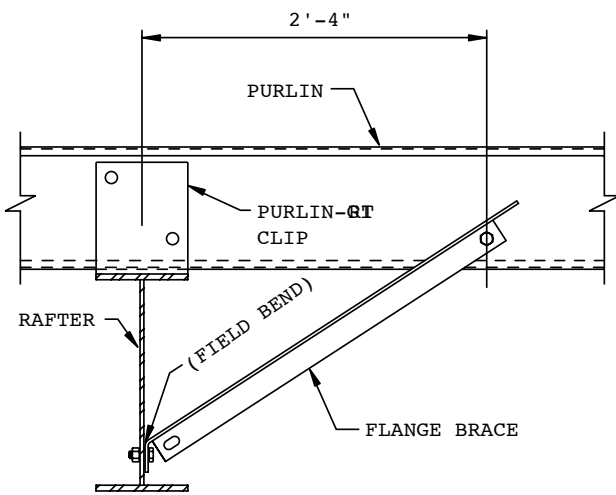

FA FLANGE BRACE CONNECTION

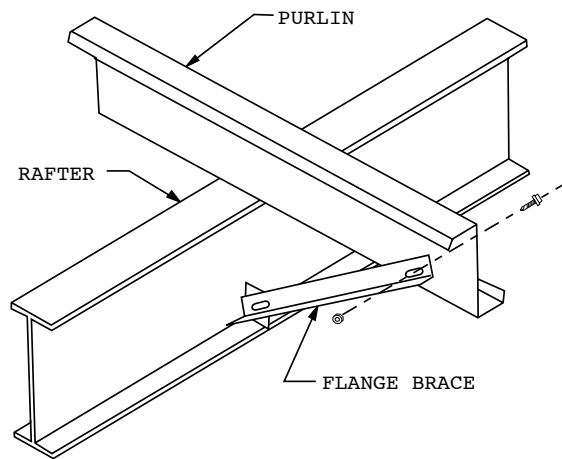

FB FLANGE BRACE CONNECTION

STEP 4

1. Bolt in place all remaining eave members, purlins, and girts of the braced bay.
2. Install brace rods and flange braces.

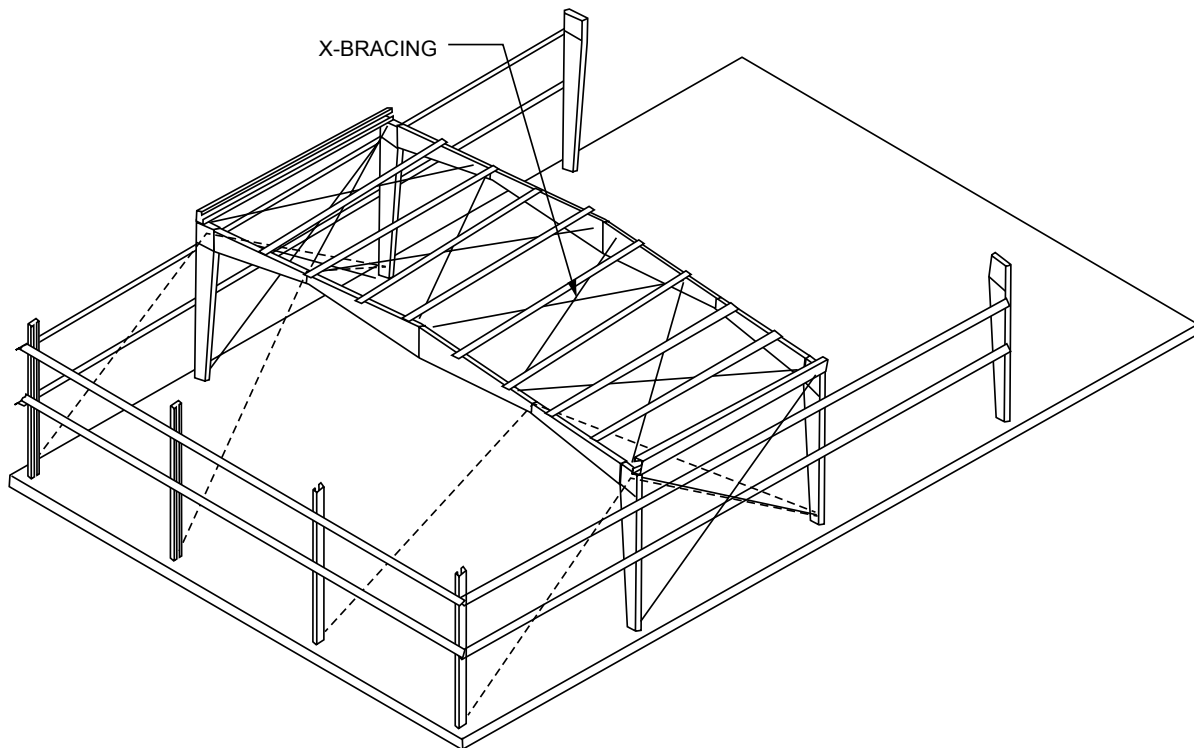

STEP 5

1. Locate transit as shown below (in this particular case slightly to the left of the first rigid frame).
2. Make sure transit is perfectly level.
3. Rotate transit until you get exactly the same tape reading at points A & B (base of columns). measure from web of column.
4. Lock horizontal rotation of transit.
5. Adjust rod bracing and temporary bracing until the tape reading at all points indicated on above sketch. Take all readings from web of column.

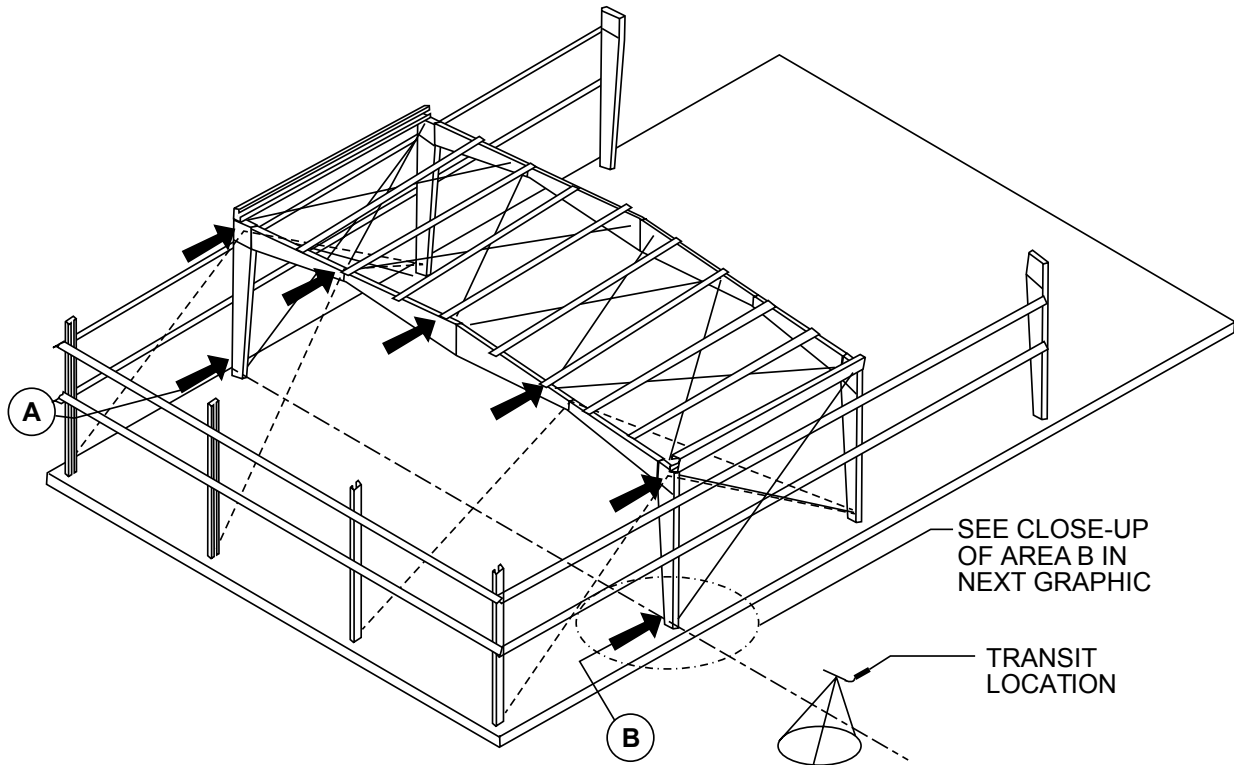

Close-Up of Area B

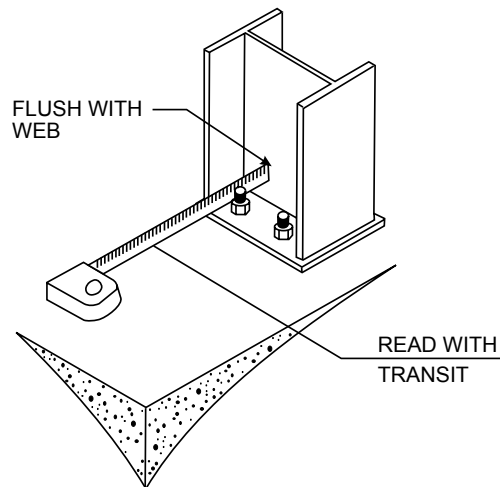

STEP 6

1. Proceed with the installation of the remaining frames.
2. Complete installation of all red iron components.
3. Note that after completion of all secondary framing in one end bay, attachment of rib panel roof may commence and be worked in conjunction with the completion of red iron.

NOTE: Remove temporary bracing only after all paneling has been installed.

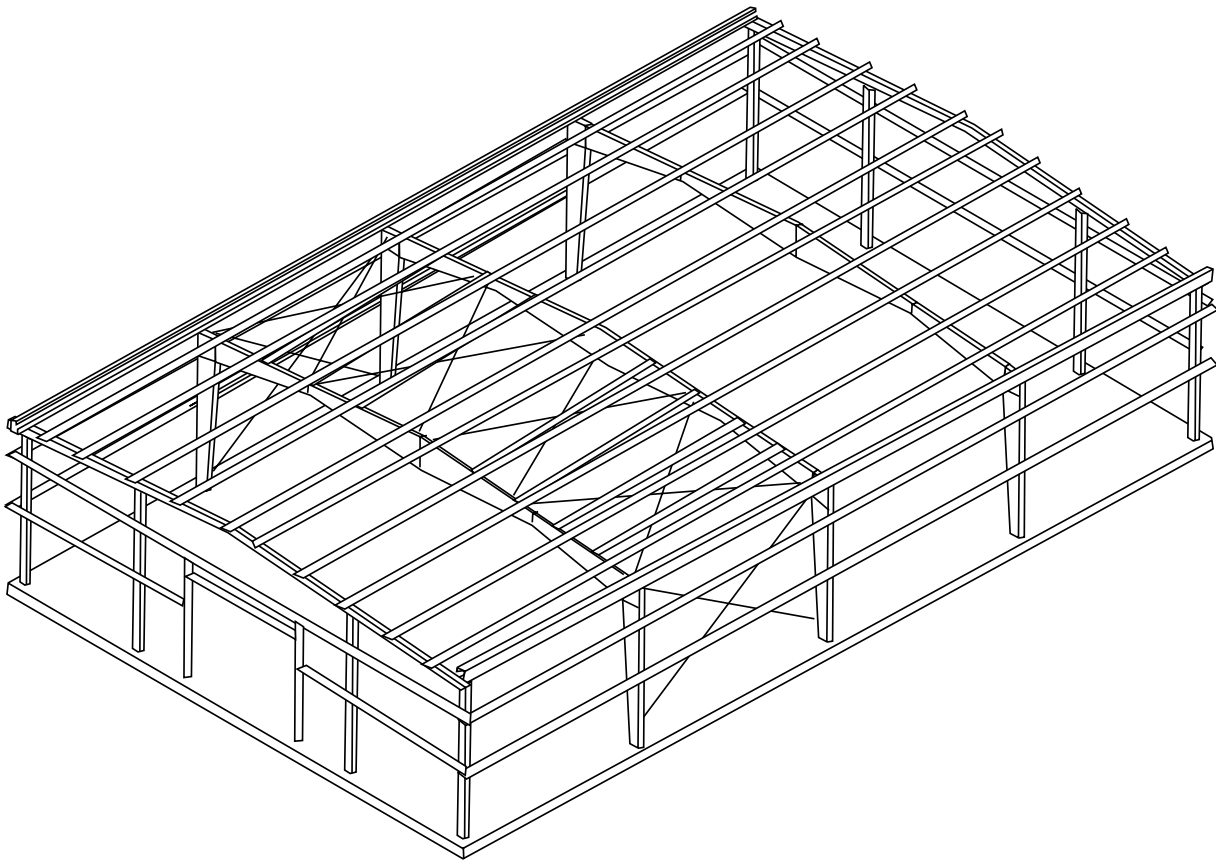

Primary and secondary framing must be plumbed and the bolts properly tightened before the sheeting of the building is started. Framed openings should also be installed, plumbed, squared, and tightened before sheeting begins.

The Manufacturer's panels are quality merchandise and must be handled with care. When unpacking panels, pick them up and apart; never slide one panel over another. When lifting panels, support long panels to prevent buckling.

NOTE: Workers should always use gloves when lifting sheets and follow all OSHA safety recommendations.

Safety First!

FASTENER INSTALLATION

Correct fastener installation is one of the most critical steps when installing panels. Drive the fastener in until it is tight and the washer is firmly seated. **Do not** overdrive fasteners. A **slight** extrusion of neoprene around the washer is a good visual check for tightness.

Always use the proper tool to install fasteners. A fastener driver (screw gun) with an RPM of 1700-2000 should be used for self-drilling screws. A 500-600 RPM fastener driver should be used for self-tapping screws. Discard worn sockets, these can cause the fastener to wobble during installation.

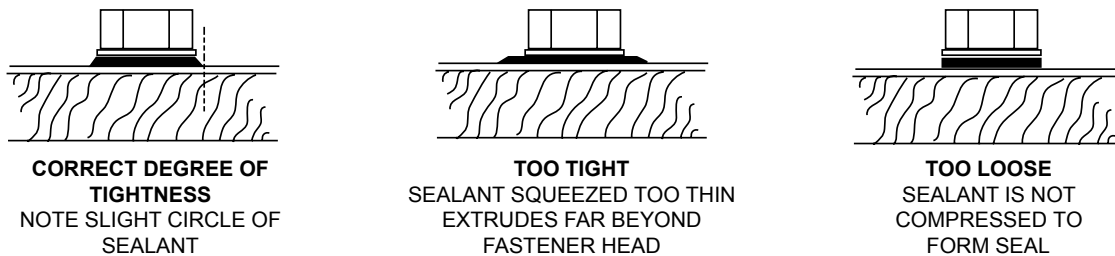

NOTE: Always remove metal filings from surface of panels at the end of each work period. Rusting filings can destroy the paint finish and void any warranty.

TAPE SEALANT

Proper tape sealant application is critical to the weather tightness of a building. Tape sealant should not be stretched when installed. Apply only to clean, dry surfaces. Only the amount of tape sealant that can be installed in one day should be placed on roof. During warm weather, store sealant in a cool dry place. During cold weather (below 60°) sealant must be kept warm (60°-90°) until application. After sealant has been applied, keep protective paper in place until panel is ready to be installed.

SCREW ALIGNMENT

Good alignment of the screws will give a professional appearance to the wall panel installation. One way this can be accomplished is by pre-drilling holes in the wall panels at identical locations. Up to 15 panels can be stacked together and drilled using a template panel. Use a 1/8" or 5/32" diameter drill bit for panel to member screws and a 1/4" diameter bit for the stitch screw clearance holes. It is important to clean metal filings off panel surfaces after drilling to avoid rust stains.

NOTE: After drilling panels, it is important to clean metal filings off all panel surfaces, including between panels that are not installed that day, to avoid rust stains.

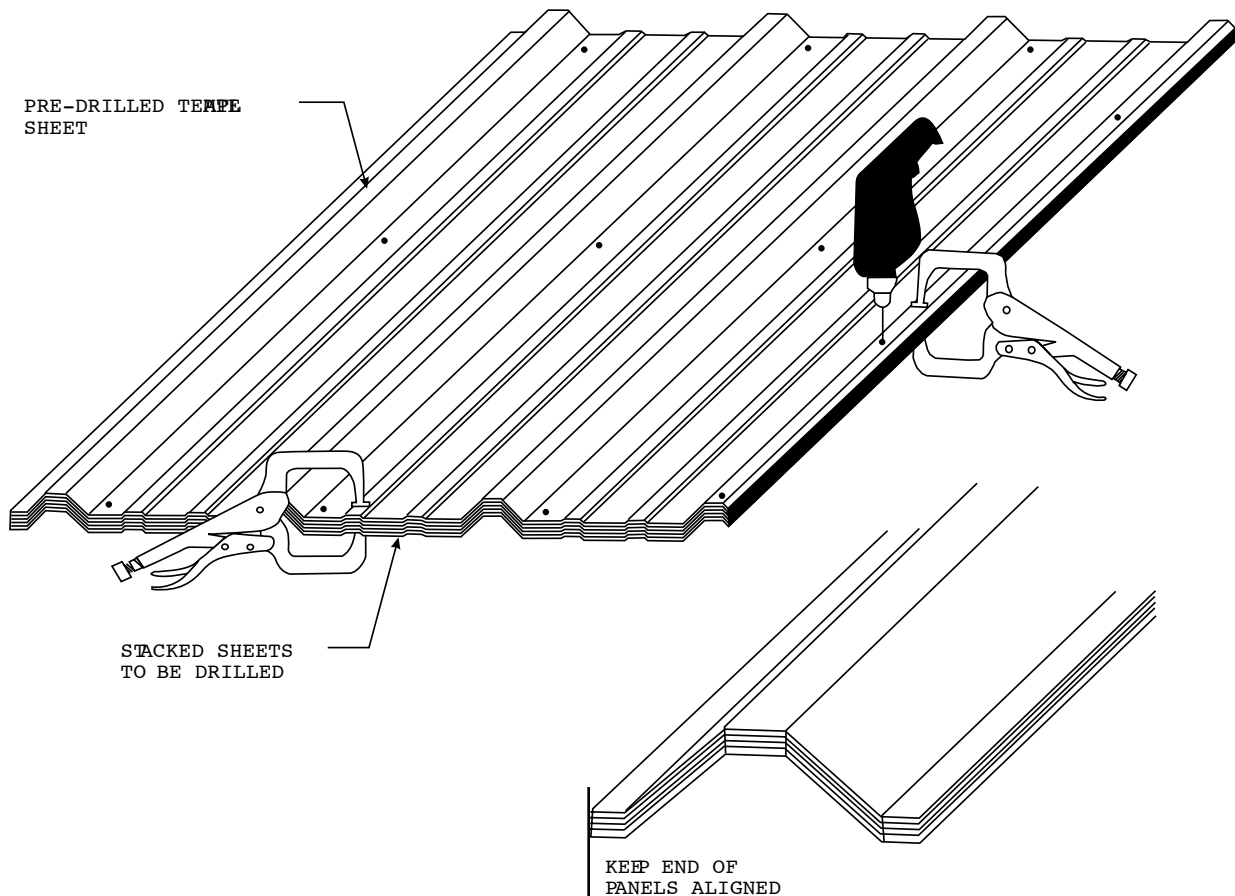

NOTE: Use **OSHA** approved eye protection when operating a drill. Electrical tools must be properly grounded. Do not use electrical tools or equipment while standing on wet surfaces.

Safety First!

The template panel should be laid out for the proper screw locations in accordance with the Building Construction Drawings. Since pre-drilling will “hand” the panels, it will also be necessary to select the end of the building from which the panel installation should begin. Before drilling the template panel it should be checked for proper hole locations against the building framework and that there is no excessive deflection in the girts.

ALIGNING THE GIRTS

Installation of the building walls is generally done before the roof. **Before starting the wall installation, check to be sure that the eave strut and girts are straight and plumb.** One method of aligning the girts is to cut temporary wood blocking to the proper length and install between the lines of girts. This blocking can be moved from bay to bay, which will reduce the number of pieces required. Normally, one line of blocking per bay will be sufficient. Banding can also be used to hold the girts straight and plumb.

NOTE: Temporary girt blocking is not recommended on concealed fastener panels. The removal of the blocks after panel installation will cause oil canning.

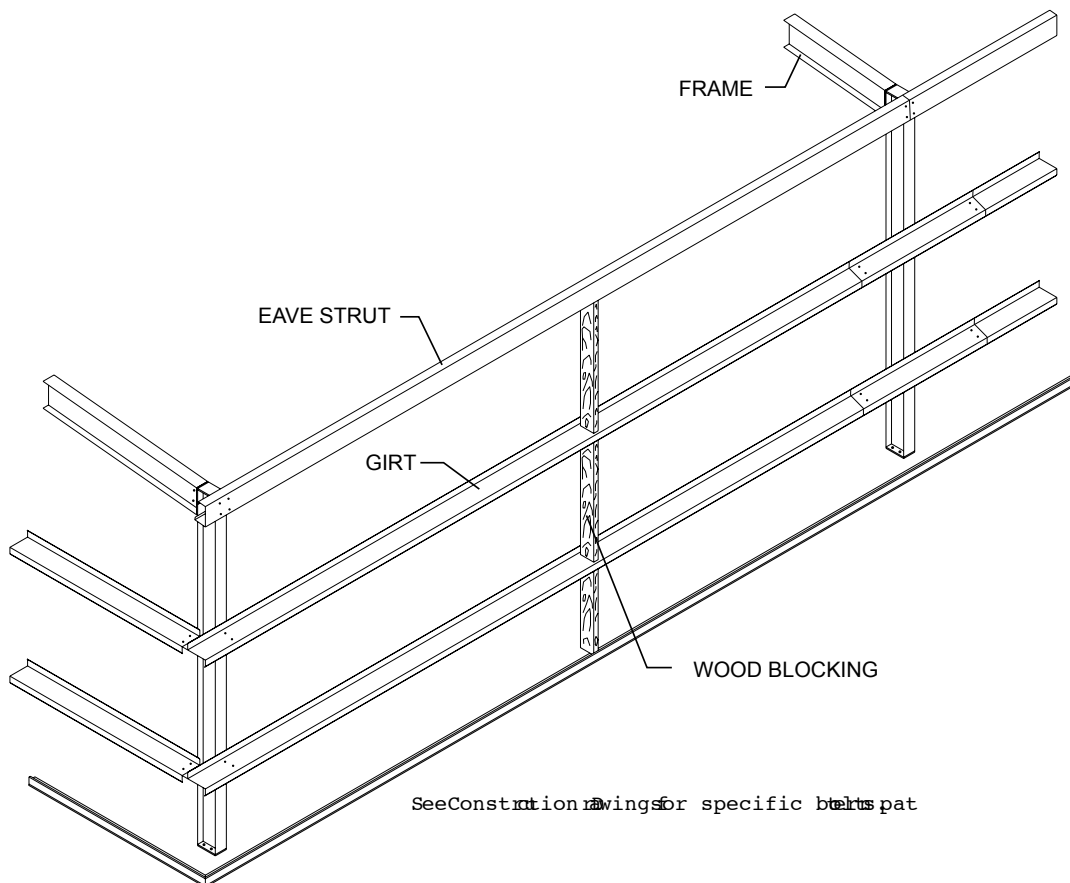

NOTE: Do not allow blocking to become a falling hazard. Workers should wear **OSHA** approved hard-hats. Girts should never be used as a climbing ladder. Damage to girt clips, as well as injury to worker may result.

Safety First!

Typical construction of the wood blocking is shown below. A 2 x 4 minimum board size should be used. Refer to the Cross Section Framing drawing that accompanied the building to determine the girt spacing.

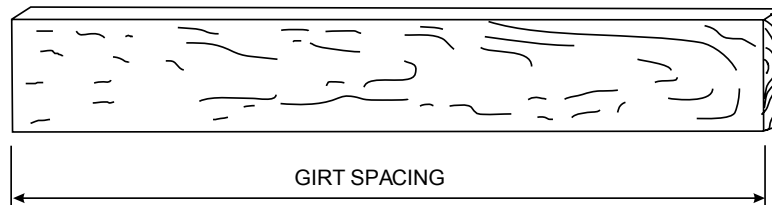

There are many types of insulation installed in pre-engineered steel buildings. However, fiberglass blanket insulation is the most common type used, and these instructions pertain to this type only. One side of the blanket insulation should have a vapor barrier that must face the inside of the building regardless of whether the insulation is for heating or cooling.

WALL INSULATION INSTALLATION

Cut the insulation to length allowing an additional 6" or more to facilitate handling. **The wall panel can be used as a guide.**

NOTE: The insulation must compress between the girt and the wall during installation. Insulation too thick or dense to compress adequately will induce waviness or oil canning in certain types of wall panels. **Oil canning is not a cause for rejection.**

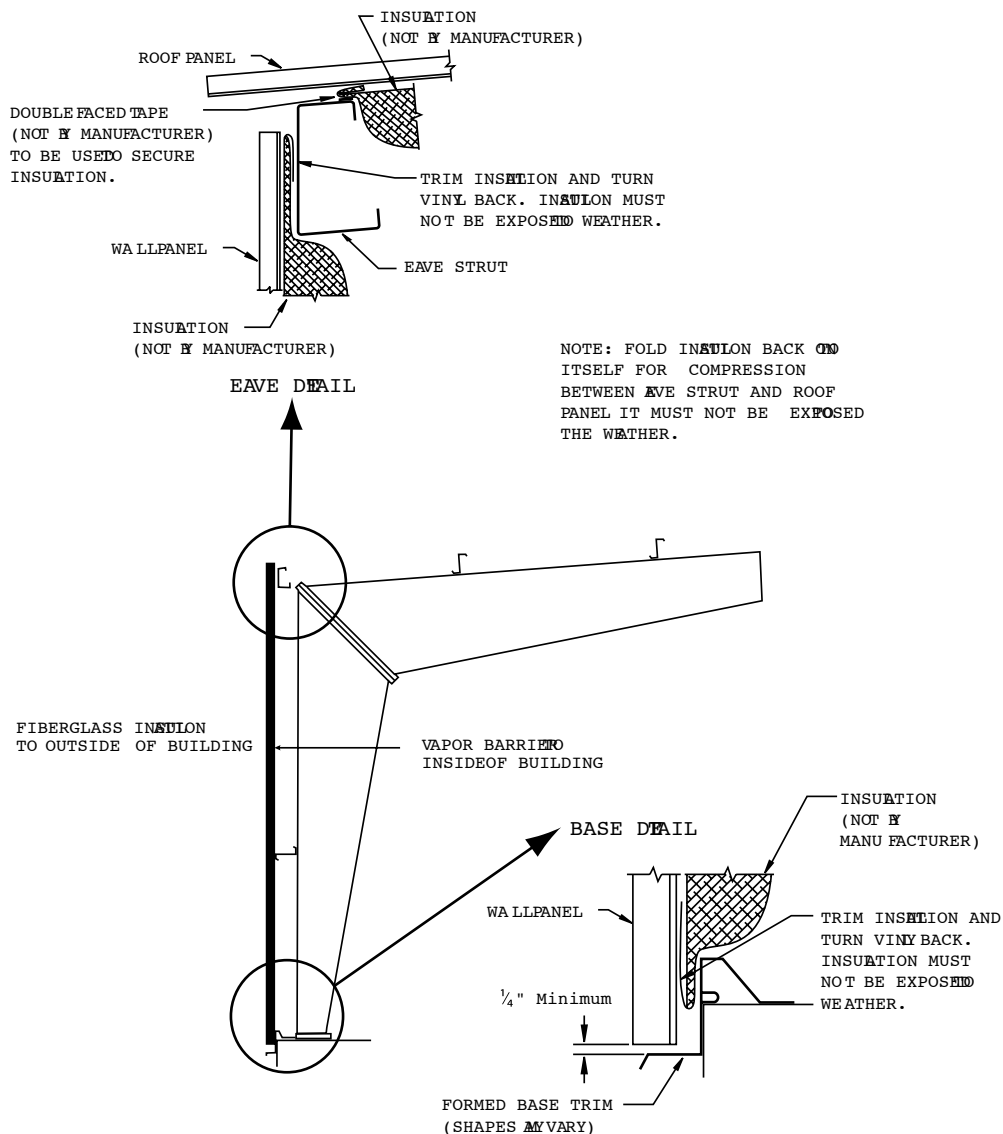

The first run of wall insulation should be installed so that its forward edge is just ahead of the leading edge of the wall panel. The most widely used procedure is to use a 4 ft. starter run, then switch to 3 ft. or 6 ft. runs. This keeps the forward edge of the insulation 1 ft. ahead of the wall panel for joining the next blanket. A minimum of 1/4" space should be allowed from the sheet end to any surface!

NOTE: Damage caused by contact with corrosive substances, or allowing panel cut edges to be in continual contact with water, i.e. setting wall panels directly on the concrete sheeting notch or base trim, is not covered under warranty.

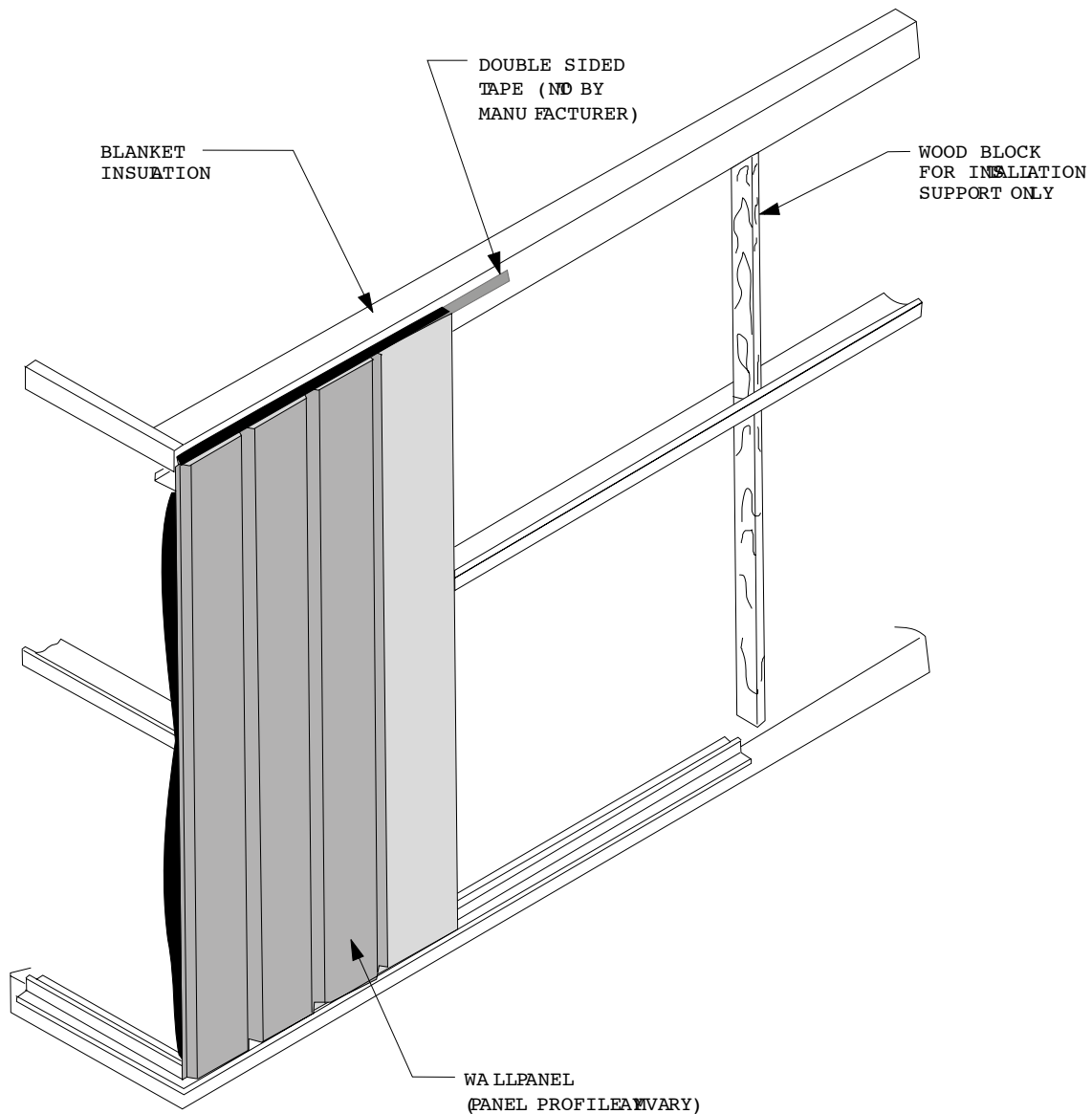

NOTE: Do not allow the insulation to wick moisture from the floor!

NOTE: Insulation has no load bearing strength. Do not lean or prop material against wall insulation. Observe all proper safety procedures when handling fiberglass insulation, such as dust masks, gloves, and long sleeved shirts, to minimize contact with the insulation fibers.

Safety First!

INSTALLATION OF WALL PANELS

Adjoining panels are installed with the pre-drilled overlapping rib toward the last erected panel. Position panel to structural making sure that it is kept plumb. Drill structural if required and install fasteners at lapped rib. Check for proper coverage and correct as necessary. Install remaining fasteners. Note that clearance holes in overlapping rib must be pre-drilled.

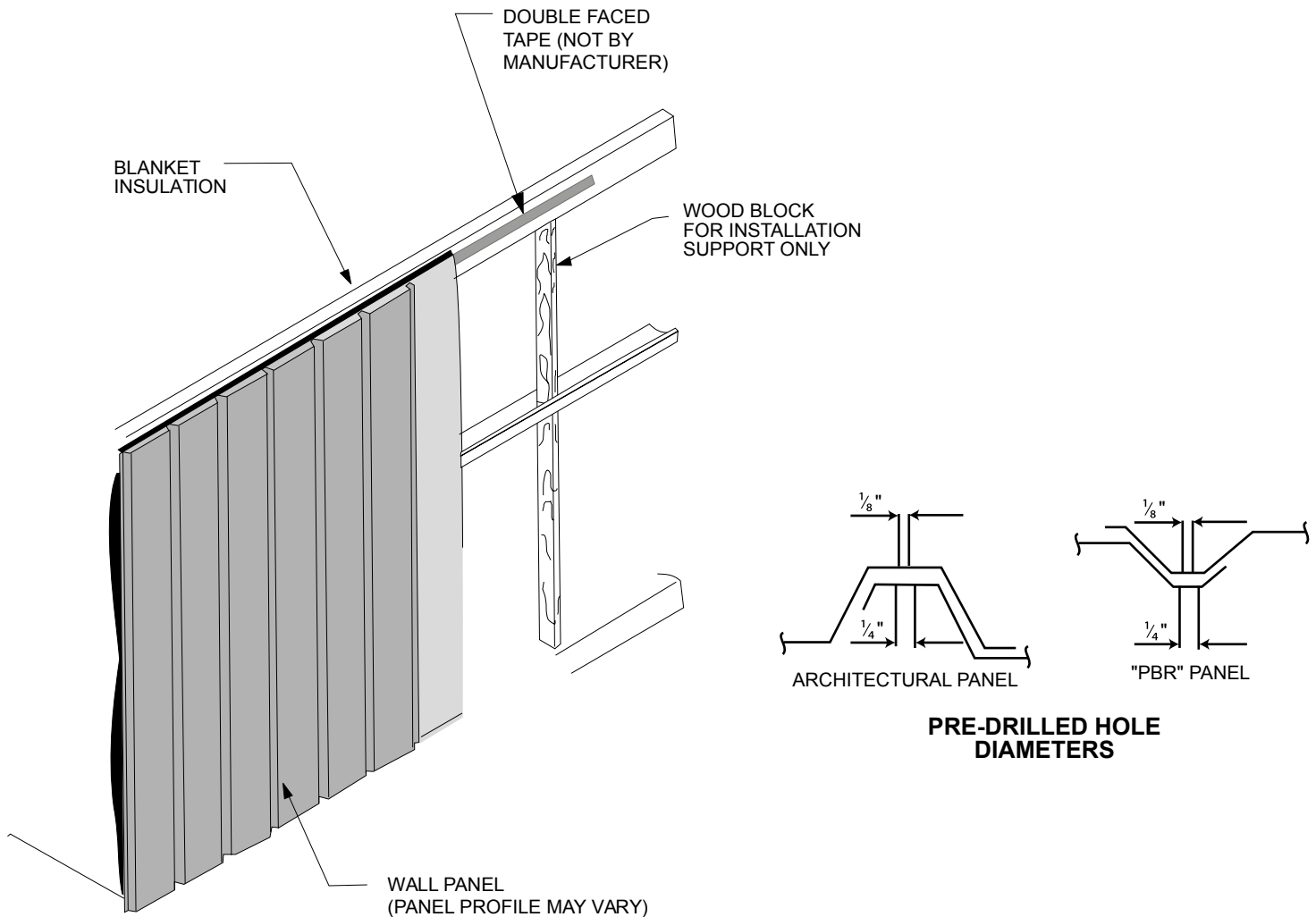

NOTE: Wear OSHA approved eye protection when operating drill. Electric tools must be properly grounded. Do not use electrical equipment while standing on wet surfaces.

Safety First!

Backlapping the panels 1 or 2 feet is routinely done to match panel coverage with the building width and length. On the sidewall this is done with the last panel installed. On the endwall this is normally done near the center and will be marked on the Construction Drawings.

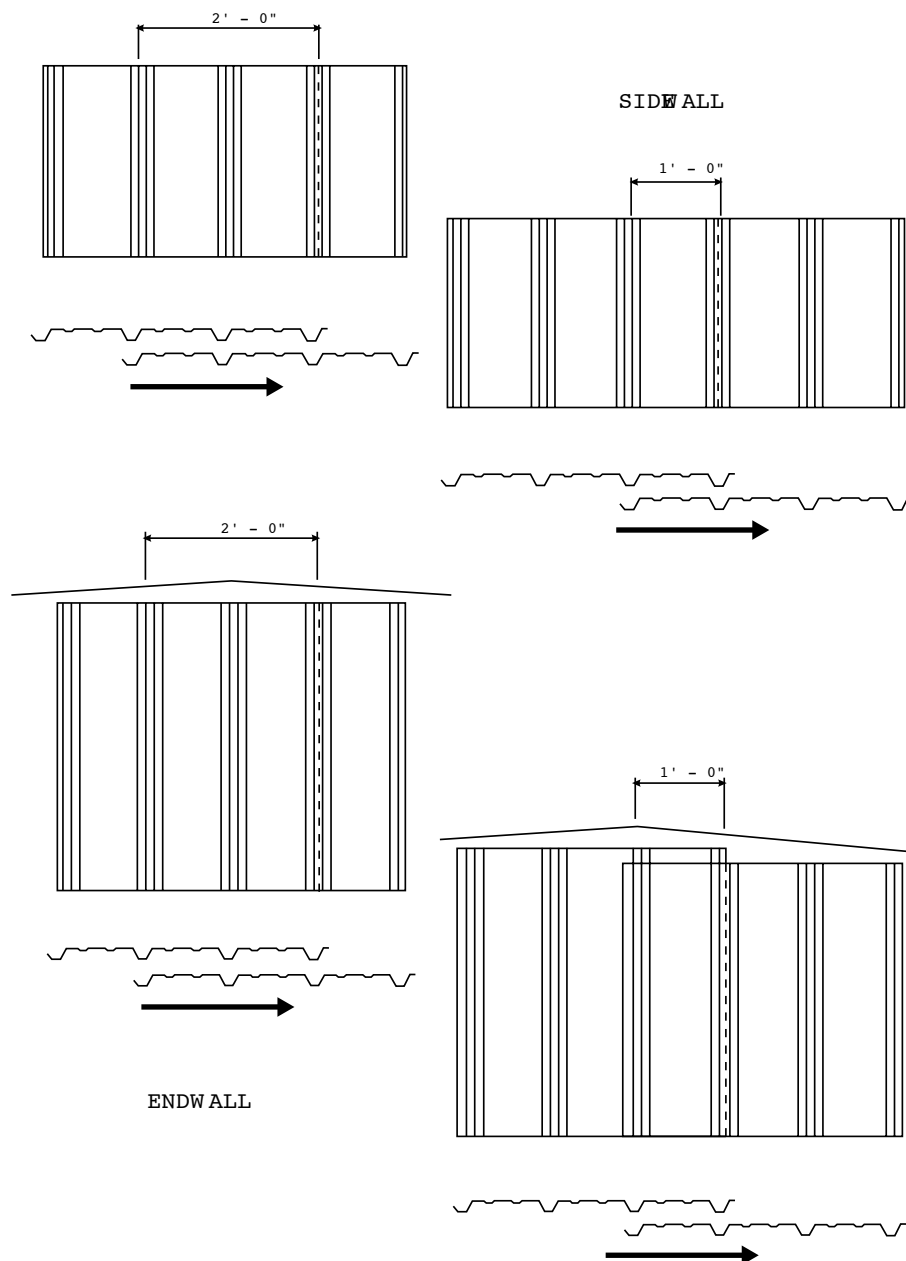

NOTE: Always follow all OSHA safety recommendations. Remember, Safety First!

The following covers rib panel roof installation. For standing seam panel roof installation see the corresponding installation manual.

After installing the wall insulation and panels, the next step is to begin the installation of the roof insulation and panels. It is essential that all building structurals be plumb and square and that the roof secondary structurals are aligned before beginning installation of the roof system. Safety is never more important than when installing the roof system. **Proper safety precautions should be followed at all times.**

Safety First!

SAFETY PRECAUTIONS FOR ROOFING WORK

The Manufacturer strongly recommends that installation employees be continuously trained and retrained in safe and productive work practices. Working on the roof area in the installation of roof structurals, insulation or roof panels requires proper training, correct equipment and constant alertness to minimize the danger of falls. Hard hats should be worn on job sites to prevent injury from falling objects. Safe work practices on all installation duties should be carefully reviewed with installation crews prior to beginning each job.



NEVER STEP ON LIGHT TRANSMITTING PANELS OR TRANSLUCENT PANELS!

Panels May Collapse If Not Properly Secured!

Roof panels must be completely attached to the purlins and to panels on either side before they can be a safe walking surface. Light transmitting panels or translucent panels can never be considered as a walking surface.

Partially attached or unattached panels should never be walked on!

Do Not:

1. Step on rib at edge of panel.
2. Step near crease in rib at edge of panel.
3. Step within 5 feet of edge on unsecured panel.

A single roof panel must never be used as a work platform. An **OSHA** approved runway should be used for work platforms! (Consult **OSHA** Safety and Health Regulations for the Construction Industry).

Safety First!

Because of the demands of the manufacturing process, oil may have been applied to the coil stock to protect the coil, as well as the finished panel during manufacturing, shipping, and storage. Metal panels must be wiped clean **prior to panel installation.**

NOTE: Always wear rubber sole work boots! When on the roof, use **OSHA** approved protection devices such as safety

Because of the demands of the manufacturing process, oil may have been applied to the coil stock to protect the coil, as well as the finished panel during manufacturing, shipping, and storage. Metal panels must be wiped clean **prior to panel installation.**

NOTE: Always wear rubber sole work boots! When on the roof, use **OSHA** approved protection devices such as safety lines, safety nets, or catch platforms.



SAFETY NOTE: CAUTION!!! PANELS MAY BE SLICK!



UNSECURED PANELS MAY SLIP IF STEPPED ON!

Employees should be continuously warned to never step on a single unsecured roof panel, or a stack of roof panels laying unattached on the purlins.

Secure each end of the panel with clamps or appropriate fasteners and place walk boards of adequate size and strength in the flat of any panels not fully secured to the purlins and supported by panels on each side. Walk boards should run the full length of the panel and be fastened together by drilling a hole near the end of each board and tied with rope to the next board.

Cut a groove in the bottom of each board so that the board will lie flat and not tip back and forth because of the rope.

SAFETY PRECAUTIONS

All safety precautions referred to throughout this manual, as well as all **OSHA** safety, other customary, or statutory requirements must be adhered to in order to maximize employee safety.

Daily meetings describing safe work procedures, use of hard hats, rubber sole shoes for roof work, proper equipment for handling material and protection devices are recommended.

Safety First!

ROOF INSULATION

Pre-cut roof insulation to reach from eave to eave. Allow approximately 2 feet of additional length to facilitate handling. Hold insulation at one sidewall and roll out insulation across the purlins, vapor barrier to the inside of the building. Stretch the insulation to provide a tight and smooth inside surface. Double sided tape or contact adhesives (Not by Manufacturer) can be used to hold insulation in place while the roof sheets are being installed.

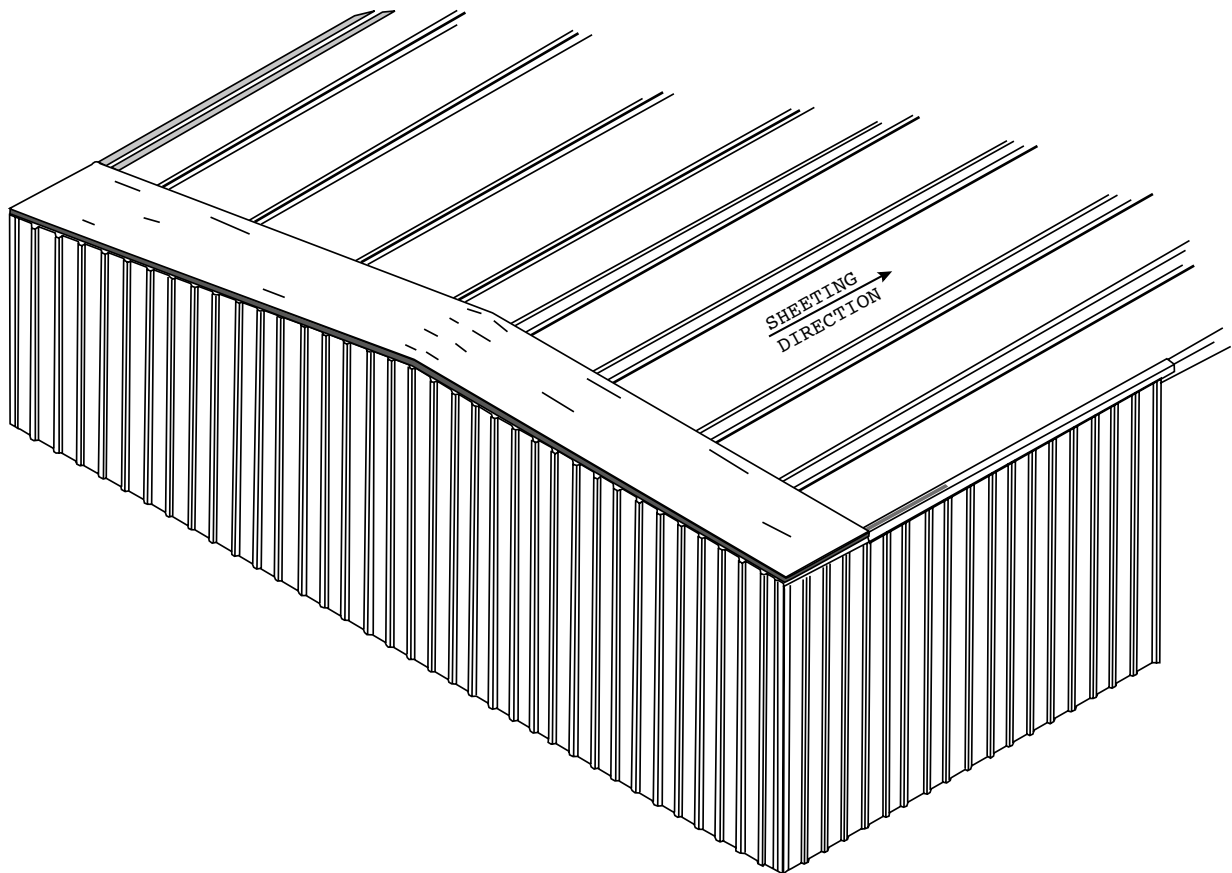

NOTE: Insulation has no load bearing strength. Maintain Body weight on approved scaffold or walk boards. Follow all **OSHA** recommended safety instructions regarding safety harnesses and/or nets to protect from falls!

Safety First!

Trim excess insulation to the edge of the eave trim and cut fiberglass approximately 4 inches from end leaving only facing. Fold facing over end of blanket insulation to seal the ends.

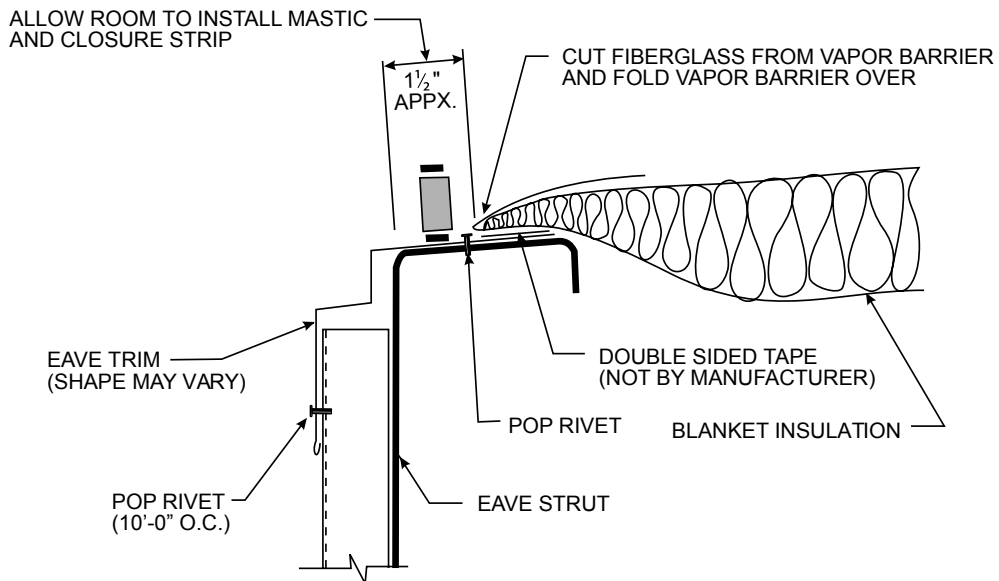

NOTE: Do not install more insulation on the roof than can be covered by roof panels before the work period ends. Do not allow the insulation to become wet.

Safety First!

A four-foot starter roll of insulation is recommended to maintain the insulation joint ahead of the sheeting edge. Seal insulation side lap joints with adhesives or fold and staple per manufacturer's instructions. As on the walls, the general sequence is to install the roof sheets in conjunction with the insulation.

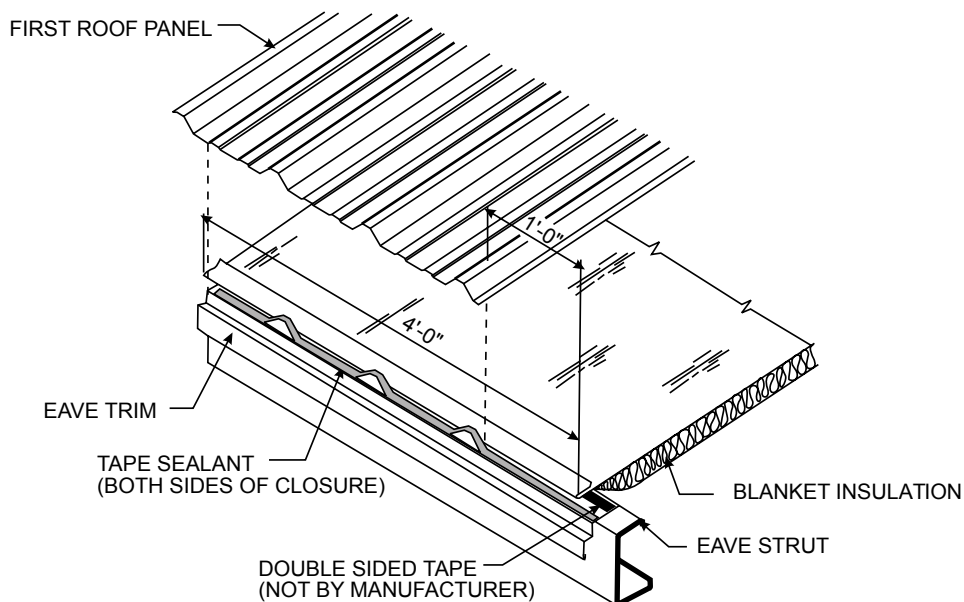

NOTE: Wipe oil and other slippery substances off panels. Do not step on rib of panel, near a crease in the panel, near a side edge or within five feet of the end of unsecured panel. Use **OSHA** approved tie-offs, netting or rails when working on roof. Insulation has no load bearing strength. Maintain body weight on approved scaffold or walk boards.

Safety First!

NOTE: The insulation side lap must be sealed to prevent condensation and minimize temperature loss at laps.

PREPARING THE EAVE

After installing the first run of insulation, prepare the eave for the first roof panel by applying tape sealant along the eave outside of the insulation and leaving release paper in place. Sealant must be applied in a straight line and without voids. **Do not stretch the sealant.** Use a knife to cut if necessary. Cut an inside closure strip as shown and place starter piece on top of the sealant (removing protective paper from the sealant only as required). Align the major rib of the closure with the edge of the endwall roofline. Splice a full closure to the starting closure and apply along the top of the eave sealant. If roof is subject to ice and snow build-up, the splice in the closure strip must be caulked to insure weathertightness.

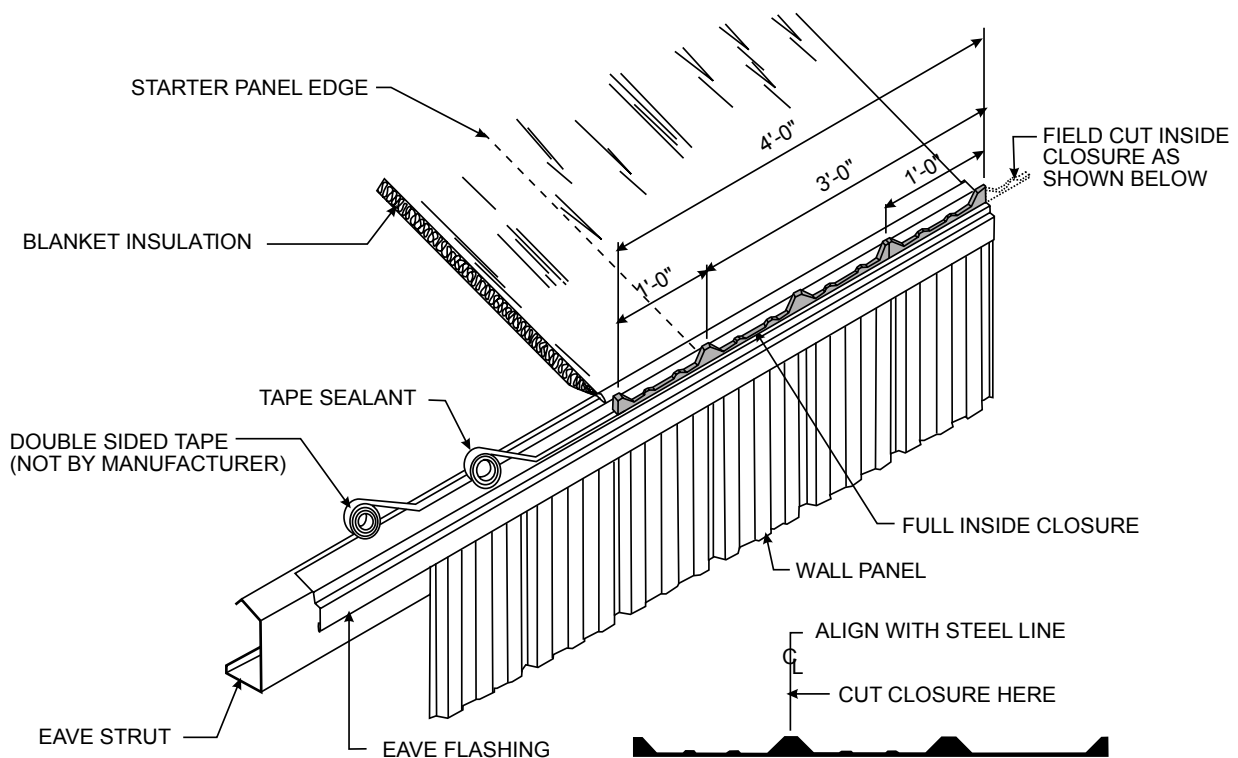

Along the top of the closures that have been placed along the eave, apply a second run of tape sealant. **Prior to removing paper backing**, check and mark for proper alignment of the first roof panel. Note that self-tapping screws require holes be drilled in the supporting structure prior to installation. Continue tape sealant and closure run along eave in preparation for the next roof panel.

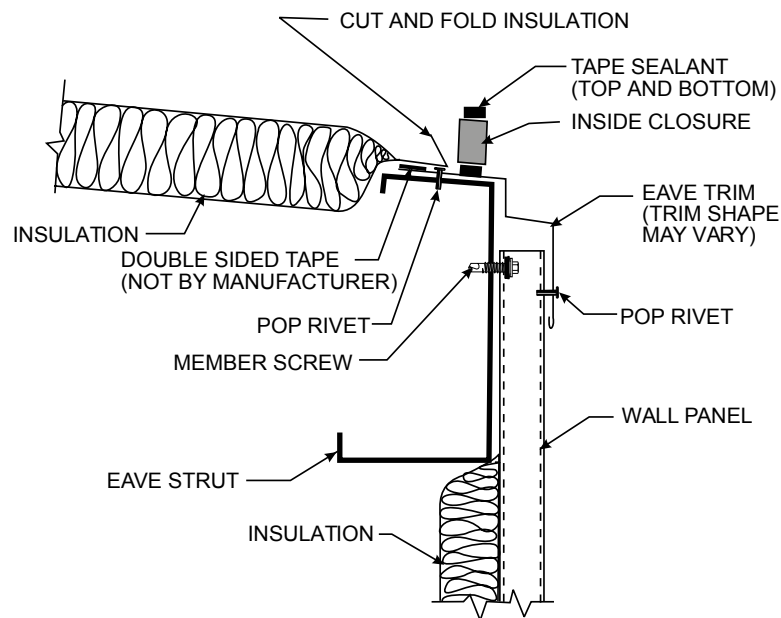

INSTALLATION OF FIRST ROOF PANEL

Once the eave is prepared, the first roof panel may be installed. Check the Construction Drawings to determine the roof overhang at the eave. Set the roof panel in place over the inside closure (after removing the paper from the tape sealant) ensuring the major ribs of the panel nest properly with the inside closure. Align the panel edge with the edge of the endwall roofline. With the panel properly placed, secure the panel to the structural with appropriate fasteners. If the building requires more than one panel per run, do not install fasteners at the purlin located at the upslope end of the panel. Lap fasteners are to be installed after the overlapped panel is installed.

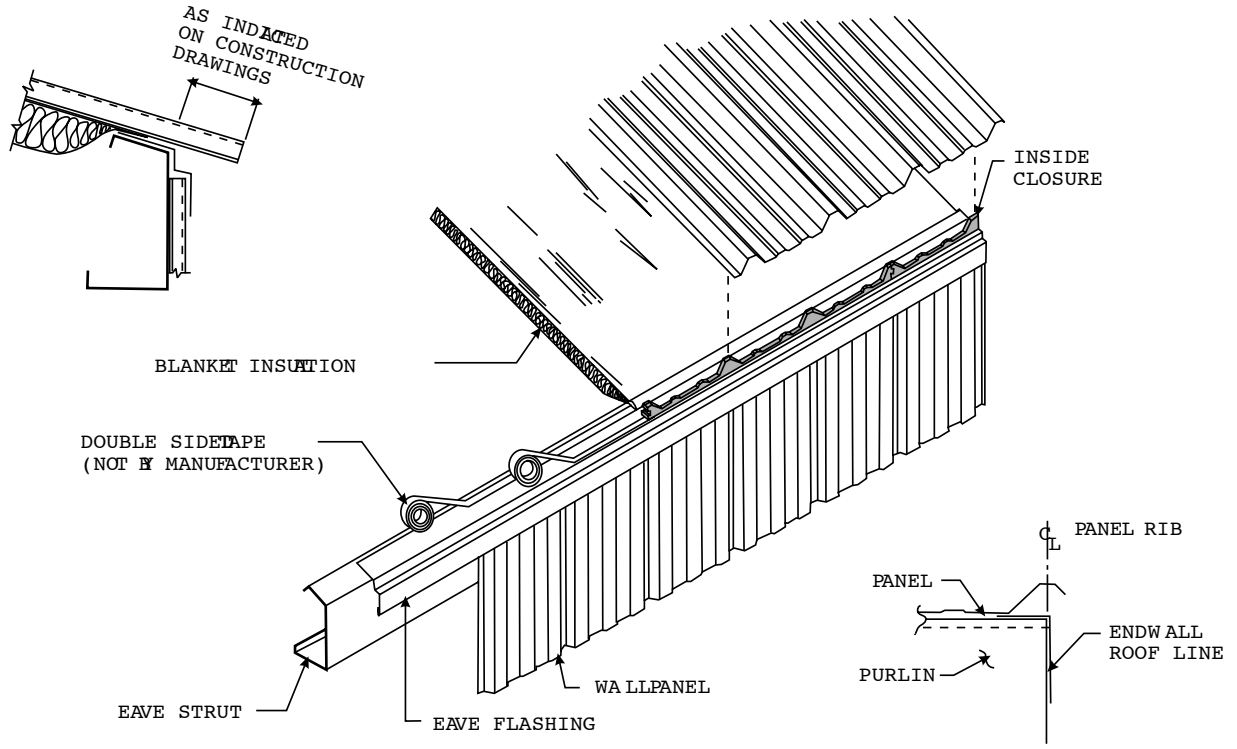

NOTE: Do not walk on unsecured panels. Wipe oil and other slippery substances from roof panels.

Safety First!

SECTION AT EAVE

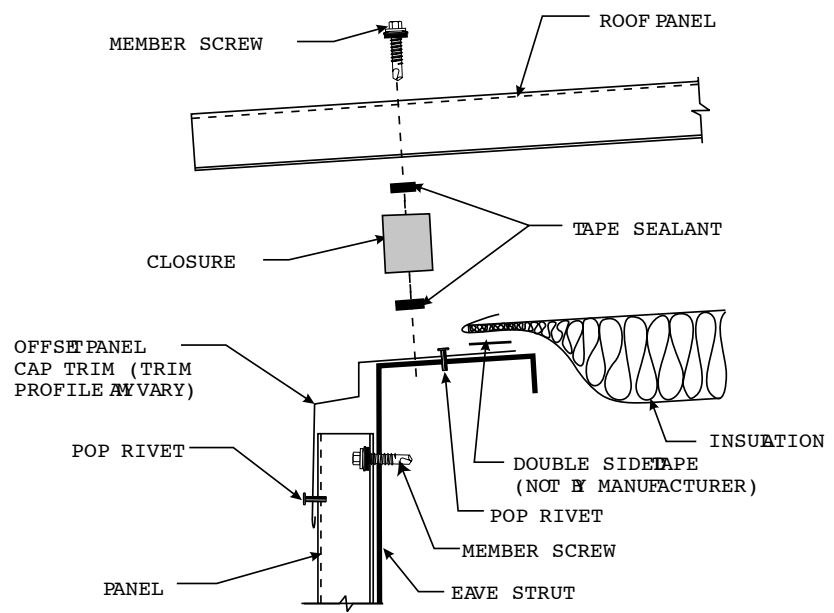

SEALING THE SIDELAP

Make sure all surfaces are clean and dry prior to installing sealants. **Apply the sidelap tape sealant to the weather side edge of the lower panel's major rib as shown.** With the release paper in place, press firmly along the length of the sealant to insure proper adhesion. While removing the protective paper from the tape sealant, care should be taken not to pull the tape sealant away from the panel. Install the adjoining panel positioning the overlapping rib with care. Drill 1/8" pilot holes for the lap fasteners at the center of the clearance holes in the overlapping panel. Stitch the lap with the stitch screws supplied with the job. **Never allow the sealant to be placed in other locations.**

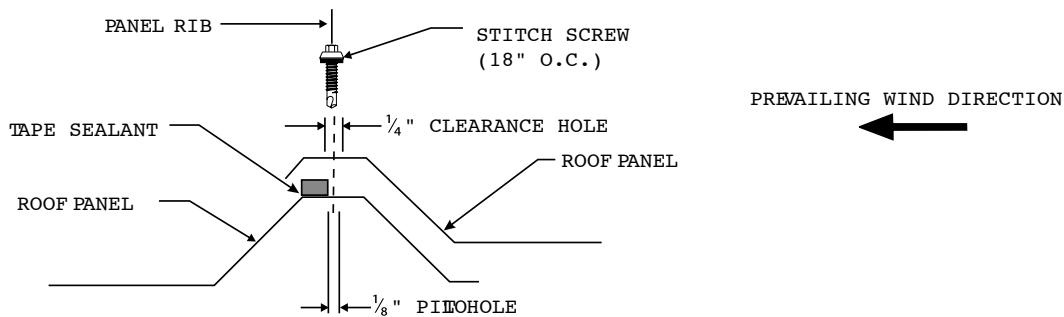

NOTE: Use **OSHA** approved eye protection when operating a drill. Sweep up all drill shavings from panels at end of each work period to minimize surface rust and damage to panel finish.

Safety First!

SEALING THE EAVE

Tape sealant location at the eave is critical. To insure a weather tight seal, the sidelap sealant must extend down from the top of the rib to the sealant on the eave closure. The sealant extension must splice into the eave tape sealant.

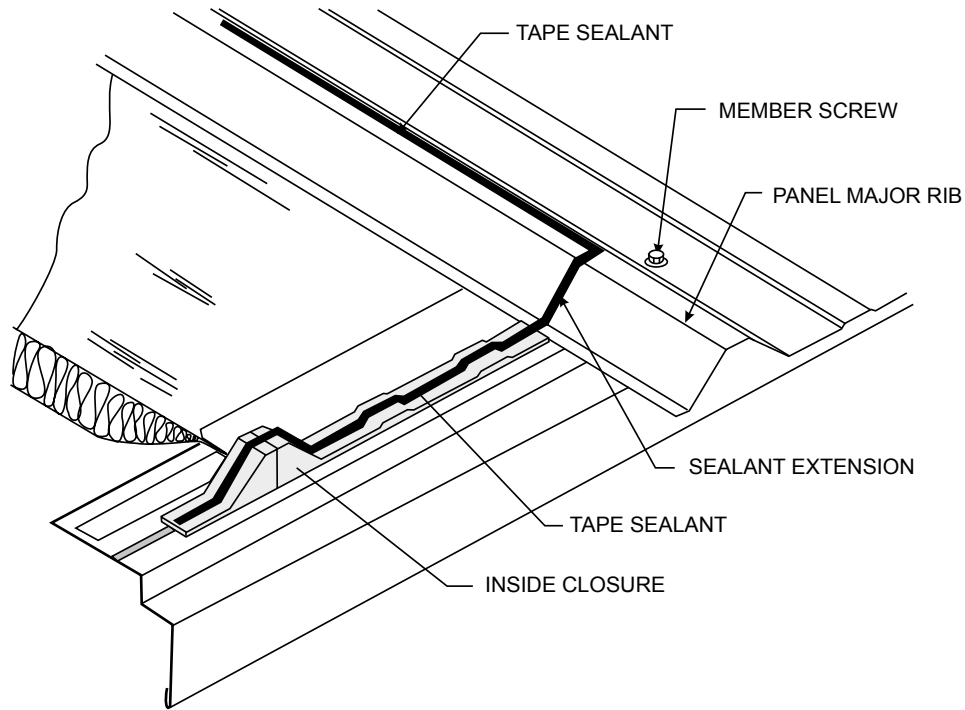

NOTE: Workers should maintain a constant awareness of their location in relation to the roof edge at all times. Follow recommended safety suggestions.

Safety First!

SEALING THE ENDLAPS

At the panel endlaps place a run of tape sealant across the full panel width 1/2" below the fastener line. The panel endlaps have a 4" minimum overlap located over a purlin as shown. Locate the fasteners 1" above the purlin web according to the fastener layout.

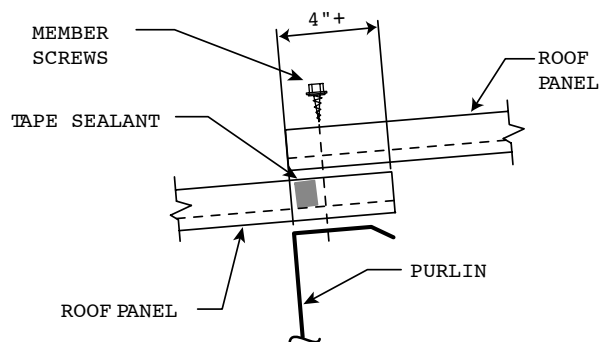

NOTE: Do not step on panel endlaps until fully secured with fasteners. Each worker should be trained to use the safest and most productive installation techniques.

Safety First!

PANEL ENDLAPS

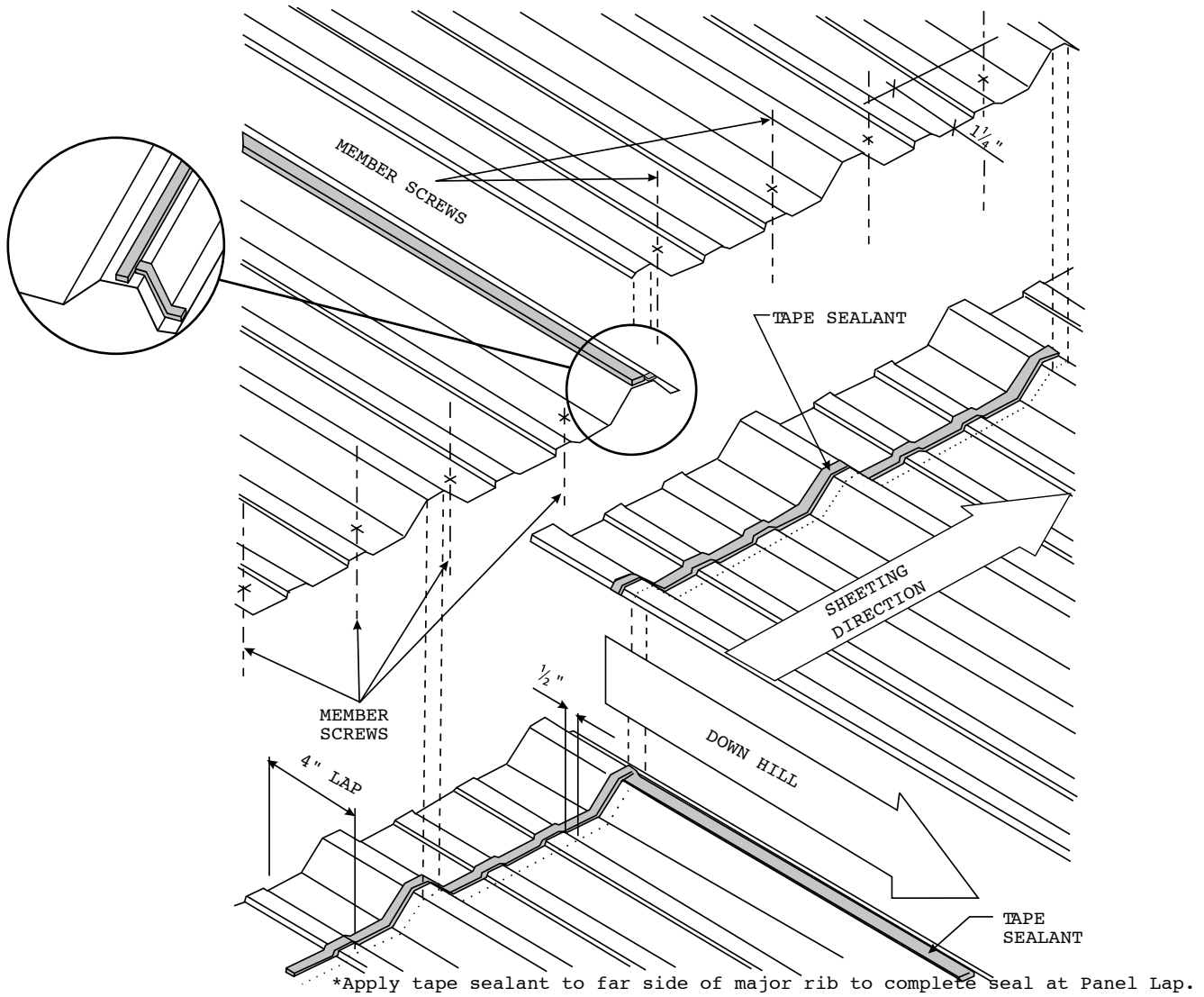

ROOF SHEETING SEQUENCE

It is recommended that both sides of the ridge of a building be sheeted simultaneously. This will keep the insulation covered for the maximum amount of time and the panel ribs can be kept in proper alignment for the ridge panel. **This is critical on the "PBR" panels so that the ridge caps can be properly installed.** Check for proper coverage as the sheeting progresses. Note panel-sheeting sequence below!

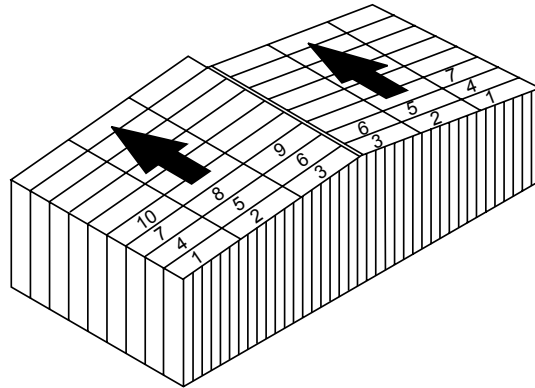

NOTE: If oil or other slippery substances are present on the roof panels, wipe them clean immediately to prevent slipping or falling. Workers must maintain a constant awareness of their location relative to the roof edge. Use **OSHA** approved tie offs, nettings or rails when working on roof surfaces.

Safety First!

RIDGE INSTALLATION

Die formed ridge panels are to be installed as each side of the roof is sheeted. This will aid in keeping both sides of the roof aligned. After having installed a run of panels on each side of the roof, apply sealant to the panels as shown. Set die formed ridge panel in place and install lap and purlin fasteners. Apply tape sealant along the top of the leading rib to prepare for the next sidelap.

NOTE: Do not walk on unsecured ends of panels.

Safety First!

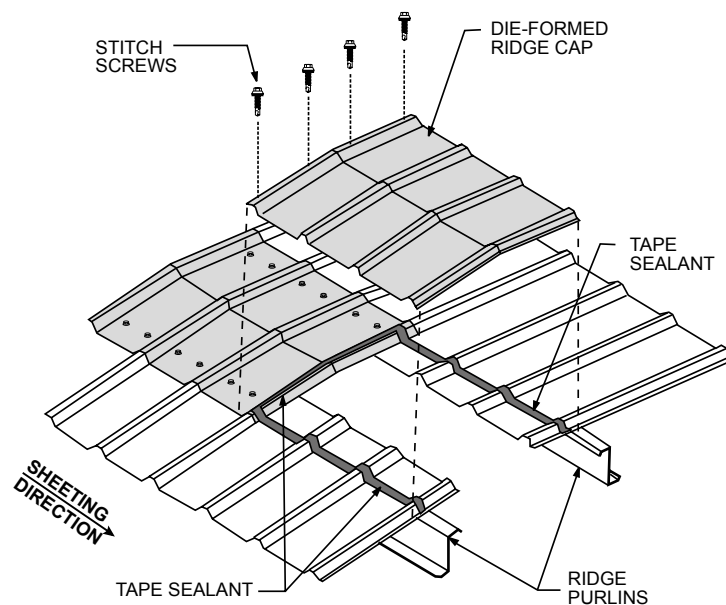

INSTALLATION OF ROOF PANELS

With the first panel run installed and secured, and sidelap sealant applied, the second panel run may be started. Prepare the eave with an inside closure and tape sealant as shown previously. Position the panel so that the overlapping ribs will nest properly. Be sure to check for proper overhang and panel coverage. Stitch the major ribs of the two panels together, and fasten panel to the purlins.

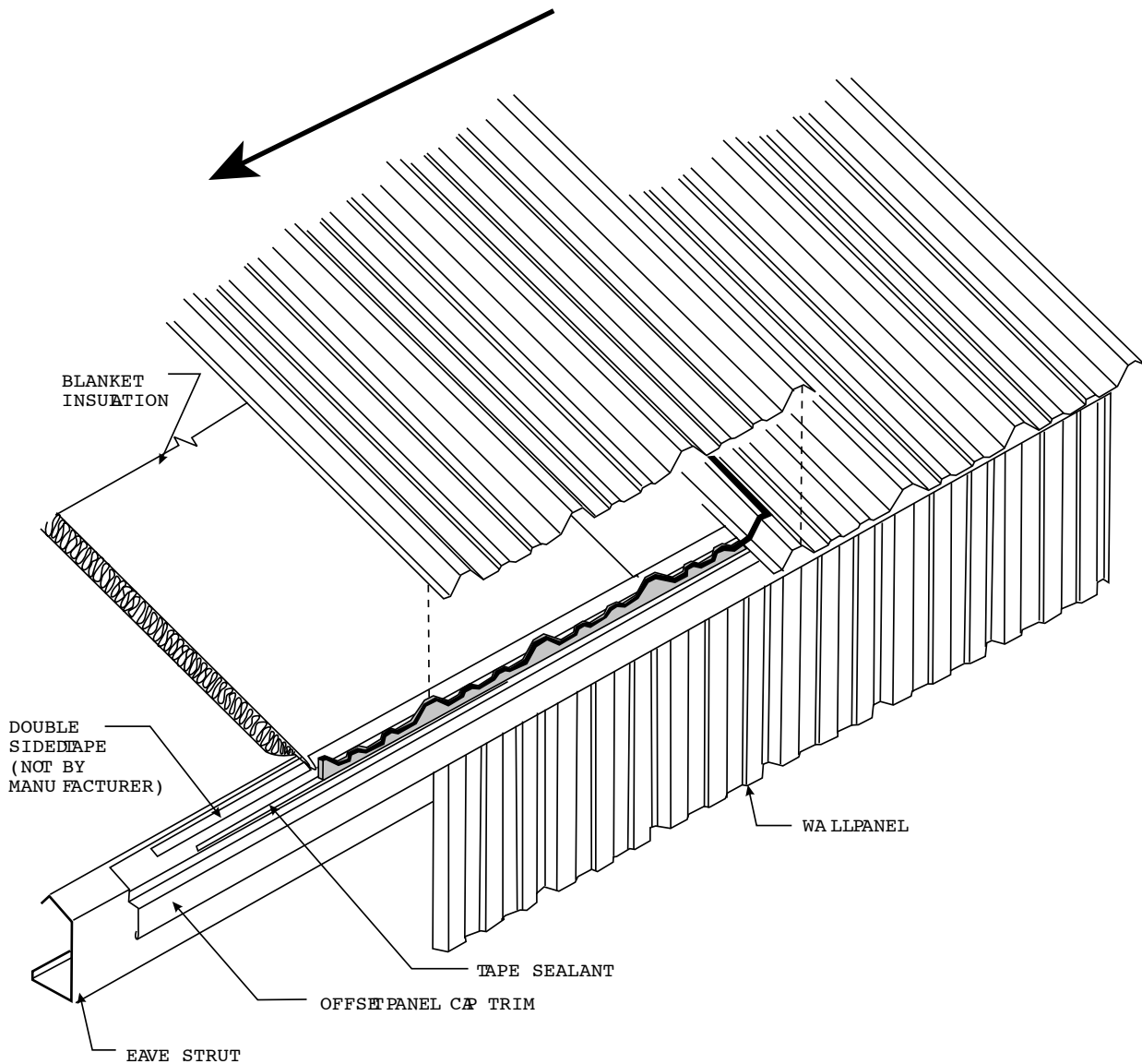

Safety First!

NOTE: Sweep up all drill shavings from panels at end of each work period to avoid surface rust and damage to panel finish.

LIGHT TRANSMITTING PANEL INSTALLATION

Light transmitting panels are installed using the same procedures as a steel panel. Care should be taken when installing fasteners in the light transmitting panels to avoid cracking the material. Pre-drill 1/4" diameter fastener clearance holes in the overlapping sidelap and endlap. Refer to your Construction Drawings for more information on light transmitting panel installation.

RECOMMENDED INSTALLATION PROCEDURE FOR INSTALLING LIGHT TRANSMITTING PANELS IN "PBR" ROOF SYSTEMS

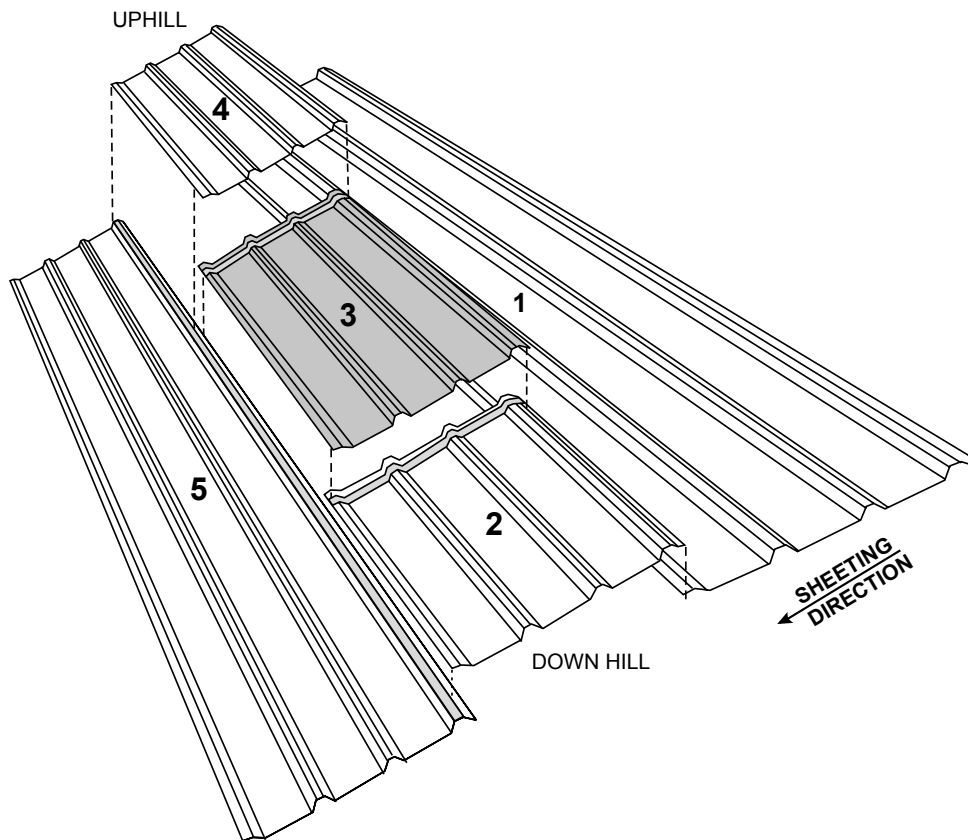

Panels are installed in sequence that corresponds with 1, 2, 3, 4, and 5.

1. Place roof panel # 1 into position and attach to the roof framing with member screws. Before panel #2 is positioned, install tape sealant along the outer edge of the panel rib on panel #1. The Tape Sealant should always be positioned to the outer edge of the panel rib so that water cannot seep into the panel lap and the stitch screws do not penetrate the sealant, which will create a void in the seal.

2. Place panel #2 in position. Secure the panel to the roof framing with member screws. **DO NOT** place any member screw on the end lap where the Light Transmitting Panel will be positioned. Do not install the last member screw at the eave. This screw will be installed later. Apply tape sealant along the end of panel # 2 where the Light Transmitting Panel will be attached. **DO NOT apply tape sealant to the right side of the panel.** Do not fasten the panels together. All side lap fasteners will be applied later.

3. Place the Light Transmitting Panel #3 in position. Attach the Light Transmitting Panel to the roof framing with member screws. Leave out the last member screw at the panel end lap. **DO NOT** attach the end of the Light Transmitting Panel to the roof member where panel #4 will be attached. Apply tape sealant to the end of the Light Transmitting Panel where panel #4 will be positioned. **DO NOT apply tape sealant to the right side of the Light Transmitting Panel.**
4. Place panel #4 in position. Secure the panel to the roof framing with member screws. Leave out the last member screw at the panel end lap. **DO NOT apply tape sealant to the right side of the panel.**
5. Apply tape sealant to the top left edge of panel #5 but do not remove the protective paper covering. Place panel #5 in position. The left panel rib of panel #5 **MUST** be positioned **UNDER** panels #2, #3, and #4. This can be accomplished by carefully lifting the edge of the panels #2, #3, and #4 and sliding panel #5 under the panels. Double check to make sure all lapses are sealed.

NOTE: THE LIGHT TRANSMITTING PANEL LAPPING RIBS MUST BE ON TOP OF BOTH SIDES.

6. Place a member screw in the end laps of panels #2, #3, and #4 that were left out. The side laps can now be fastened using stitch screws at 20" O.C.
7. Continue sheeting the roof.

NOTE: Do not under any circumstances step or walk on surface of light transmitting panel. If foot traffic is necessary over light transmitting panel, use walk boards that are properly supported by building purlins. Placing of "DANGER, DO NOT WALK" markings on every light transmitting panel must be done without fail.

Safety First!

INSTALLATION OF FINAL PANEL

While backlapping the last roof panel (to match panel coverage with the building length) is routinely done, this installation method can compromise the integrity of the roof by trapping moisture between the panels. This moisture could, in time, create an environment conducive to rust and metal failure. The Manufacturer recommends field cutting the final panel lengthwise to create the desired panel width necessary to finish off the building. The cut edge of the panel should always be installed on the outside edge, not the lap edge. The "field-cut" panel should be handled with care, and foot traffic avoided until the final panel is completely installed.

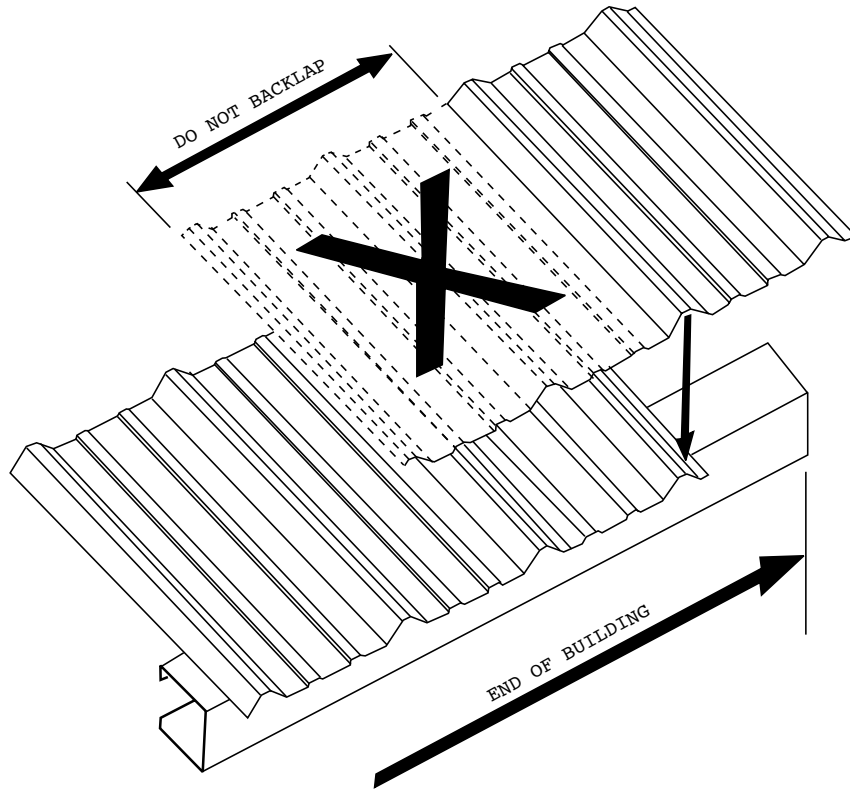

The correct installation of flashing, gutters, and trim cannot be overemphasized. The overall appearance of the finished building depends primarily on the quality of the installation of the flashing, gutters, and trim. Keep all gutter and flashing lines straight. Make all bends sharp and neat. Be sure edges are not jagged, dented, crimped, or serrated. End joints and laps must be closely controlled.

See Construction Drawings for Installation of Trim and Accessories Drawings.

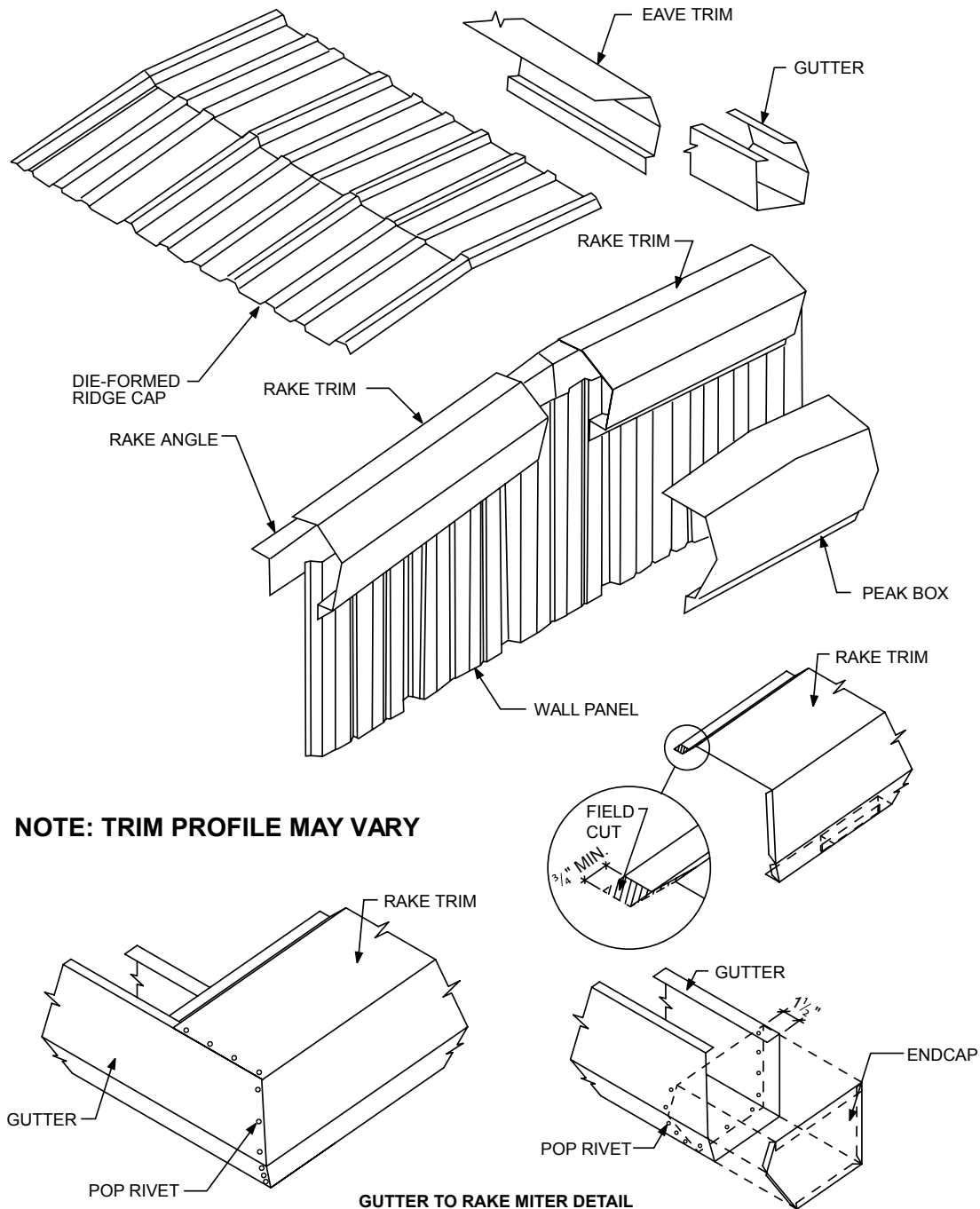

STRIPPABLE FILM NOTICE

A strippable film has been added to preserve the color-finish during manufacturing and shipment. This film **MUST BE COMPLETELY REMOVED PRIOR TO INSTALLATION OF PRODUCT.** If product is not immediately installed, the strippable film must be removed within 7 days if exposed to sunlight. If not exposed to sunlight the strippable film must be removed within 30 days. Failure to comply with this "NOTICE" may result in deterioration of the color finish and impair the ability to remove the film, nullifying the warranty in part or total.

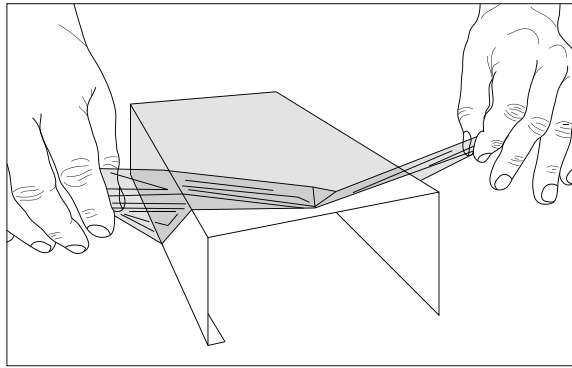

LIFT FILM FROM END OF PRODUCT APPROXIMATELY 1" AROUND ENTIRE PIECE.

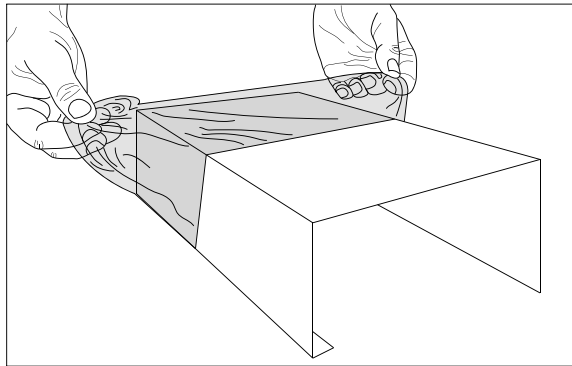

GRAB BOTH SIDES OF LIFTED FILM AND PULL STRAIGHT BACK OVER ITSELF COMPLETELY DOWN ENTIRE LENGTH OF PRODUCT.

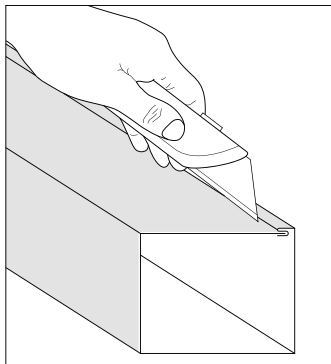

IN SITUATIONS WHERE STRIPPABLE FILM IS FORMED INTO A HEM, LIKE ON DOWNSPOUTS, SCORE FILM AT HEM WITH UTILITY KNIFE THE COMPLETE LENGTH OF PRODUCT BEFORE LIFTING AND REMOVING FILM.

Headquarters

6451 North Federal Highway,
Suite 1204
Fort Lauderdale, Florida 33308
T. 1 (877) 9978335
D. 1 (954) 5904955
F. 1 (954) 9037970

Orlando

111 North Orange Avenue,
Suite 1175
Orlando, Florida 32801
T. 1 (800) 5082718
D. 1 (407) 5630703
F. 1 (407) 3742747

Panama

International Business Park
Building 3845, 3rd Floor,
Unit 301
Panamá Pacífico, Arraiján,
Panama
T. (507) 8336940